



NoTube

*Networks and ontologies for the transformation and unification of broadcasting
and the Internet*

FP7 – 231761

D2.2 Metadata conversion concept and prototype implementation

**Coordinators: Peter Altendorf, Matthias Elser, Martin
Riethmayer, Rico Zimmermann**

**With contributions from: Raoul Monnier, Anne-Lore
Mevel, Peter Altendorf, Martin Riethmayer, Matthias
Elser, Rico Zimmermann, Libby Miller.**

Quality Assessor: Fulvio Negro

Quality Controller: Peter Altendorf

Document Identifier:	NoTube/2010/D2.2 /v.1.0
Version:	V1.0
Date:	15. December 2010
State:	Final
Distribution:	open

EXECUTIVE SUMMARY

This deliverable is dedicated to provide an overview of the specified metadata conversions and their implementations, which are needed inside the NoTube platform. Furthermore the re-assessment of the requirements regarding the metadata amount and the appropriate computation is described for the three use cases. Corresponding to the different requirements, WP2 will provide dedicated transformation services. This deliverable presents the underlying components of these services, which are used for the TV metadata interoperability in NoTube.

DOCUMENT INFORMATION

IST Project Number	FP7 - 231761	Acronym	NoTube
Full Title	Networks and ontologies for the transformation and unification of broadcasting and the Internet		
Project URL	http://www.notube.tv/		
Document URL			
EU Project Officer	Leonhard Maqua		

Deliverable	Number	2.2	Title	Metadata conversion concept and prototype implementation
Work Package	Number	2	Title	TV Metadata Interoperability

Date of Delivery	Contractual	M 23	Actual	
Status	version 1.0		final <input type="checkbox"/>	
Nature	prototype <input type="checkbox"/> report <input type="checkbox"/> dissemination <input type="checkbox"/>			
Dissemination level	public <input type="checkbox"/> consortium <input type="checkbox"/>			

Authors (Partner)	Matthias Elser (IRT), Anne-Lore Mevel (TGV), Libby Miller (BBC), Raoul Monnier (TGV), Martin Riethmayer (IRT), Rico Zimmermann (IRT)			
Responsible Author	Name	Peter Altendorf	E-mail	altendorf@irt.de
	Partner	IRT	Phone	+49 89 32399-271

Abstract (for dissemination)	The document describes the TV metadata conversion and access components that are underlying the TV metadata services WP2 is providing in NoTube.
Keywords	TV metadata transformation, metadata conversion service, metadata mapping

Version Log			
Issue Date	Rev. No.	Author	Change
22.11.2010	0.1	Matthias Elser, Martin Riethmayer, Rico Zimmermann	Initial version of the document
29.11.2010	0.2	Anne-Lore Mevel, Raoul Monnier, Libby Miller	Contributions from BBC and TGV
03.12.2010	0.3	Matthias Elser, Martin Riethmayer, Rico Zimmermann	Final version for Quality Assessment
10.12.2010	0.4	Matthias Elser, Rico Zimmermann	Incorporating the reviewer's comments
15.12.2010	1.0	Martin Riethmayer, Peter Altendorf	Final version

PROJECT CONSORTIUM INFORMATION

Participants		Contact
Vrije Universiteit Amsterdam		Guus Schreiber Phone: +31 20 598 7739/7718 Email: schreiber@cs.vu.nl
British Broadcasting Corporation		Libby Miller Phone: +44 787 65 65 561 Email: Libby.Miller@bbc.co.uk
Asemantics SRL Uninominale		Alberto Reggiori Phone: +39 0639 7510 78 Email: alberto@asemantics.com
Engin Medya Hizmetleri A.S.		Ron van der Heiden Phone: +31 6 2003 2006 Email: ron@engin.tv
Institut fuer Rundfunktechnik GmbH		Christoph Dosch Phone: +49 89 32399 349 Email: dosch@irt.de
Ontotext AD		Atanas Kiryakov Phone: +35 928 091 565 Email: naso@sirma.bg
Open University		John Domingue Phone: +44 1908 655 014 Email: j.b.domingue@open.ac.uk
RAI Radiotelevisione Italiana SPA		Alberto Morello Phone: +39 011 810 31 07 Email: a.morello@rai.it
Semantic Technology Institute International		Lyndon Nixon Phone: +43 1 23 64 002 Email: lyndon.nixon@sti2.org
Stoneroos B.V.		Annelies Kaptein Phone: +31 35 628 47 22 Email: annelies.kaptein@stoneroos
Thomson Grass Valley France SA		Raoul Monnier Phone: +33 2 99 27 30 57 Email: raoul.monnier@thomson.nett
TXT Polymedia SPA		Sergio Gusmeroli Phone: +39 02 2577 1310 Email: sergio.gusmeroliqtxtgroup.com
KT Corporation		Myoung-Wan Koo Phone: +82 2 526 6347 Email: mskim@kt.co.kr

TABLE OF CONTENTS

LIST OF FIGURES	7
LIST OF TABLES	8
LIST OF ABBREVIATIONS.....	9
1. INTRODUCTION	10
2. REQUIREMENTS	10
2.1. RE-ASSESSMENT OF REQUIREMENTS FROM USE CASE 7A	10
2.2. RE-ASSESSMENT OF REQUIREMENTS FROM USE CASE 7B	12
2.3. RE-ASSESSMENT OF REQUIREMENTS FROM USE CASE 7C	13
3. TV METADATA CONVERSION COMPONENTS.....	15
3.1. PRESTOSPACE2BMF	15
3.1.1. CONCEPTUAL MAPPING.....	15
3.1.2. SOFTWARE COMPONENTS.....	15
3.2. BMF2TVA	17
3.2.1. CONCEPTUAL MAPPING.....	17
3.2.2. SOFTWARE COMPONENTS.....	17
3.3. EGTA2TVANYTIME COMPONENT.....	19
3.3.1. CONCEPTUAL MAPPING.....	19
3.3.2. SOFTWARE COMPONENT	19
4. TV METADATA <i>CRUD</i> COMPONENTS.....	21
4.1. <i>CRUD</i> ARCHITECTURE.....	21
4.2. <i>CRUD</i> INTERFACES.....	22
4.3. TVA- <i>CRUD</i> COMPONENT.....	24
4.4. NIC- <i>CRUD</i> COMPONENT	25
5. EVALUATION.....	26
5.1. TECHNICAL EVALUATION	26
5.1.1. EVALUATION FOR USE CASE 7A	26
5.1.2. EVALUATION FOR USE CASE 7B.....	26
5.2. USER EVALUATION	26
6. CONCLUSION.....	27
REFERENCES.....	28
APPENDIX.....	29
A TVA-<i>CRUD</i> COMPONENT.....	29
A.1 TVA- <i>CRUD</i> INTERFACES	29
A.2 TVA- <i>CRUD</i> CLASS DIAGRAMS.....	30
B NIC-<i>CRUD</i> COMPONENT.....	32
C PRESTOSPACE / BMF MAPPING TABLE.....	33
D BMF / TV-A MAPPING TABLE.....	37

E EGTA / TV-A MAPPING TABLE40

List of Figures

Figure 1 : Component structure for the <i>PrestoSpace</i> to BMF transformation	16
Figure 2 : Components for the BMF to TVA transformation.....	18
Figure 3 : XSLT-Process of the <i>EGTA2TVAnytime</i> component	19
Figure 4 : Overview <i>CRUD</i> architecture	21
Figure 5 : TVA-CRUD component interfaces.....	29
Figure 6 : TVA-CRUD component class diagram 1	30
Figure 7 : TVA-CRUD component class diagram 2	31
Figure 8 : NIC-CRUD component interfaces.....	32

List of Tables

Table 1 : NIC - Generic information	11
Table 2 : NIC – Attractor information.....	11
Table 3 : NIC – Content description	11
Table 4 : NIC – Facet description	12
Table 5 : NIC – Management information	12
Table 6 : Requirements to metadata used by use case 7b – Content description	12
Table 7 : Requirements to metadata used by use case 7b – Technical metadata.....	13
Table 8 : Requirements to metadata used by use case 7b – Intended audience description.....	13
Table 9 : Interfaces for the NIC – Content.....	22
Table 10 : Interfaces for the NIC – <i>ContentInfo</i>	22
Table 11 : Interfaces for the NIC – <i>Attractors</i>	23
Table 12 : Interfaces for the NIC – <i>Facets</i>	23
Table 13 : Interfaces for the NIC – <i>Derivation</i>	23
Table 14 : Interfaces for the NIC – <i>ShapeLayer</i>	24
Table 15 : Interfaces for the NIC – <i>RepresentationLayer</i>	24
Table 16 : Interfaces for the NIC – <i>Management</i>	24
Table 17 : Mapping table PrestoSpace / BMF.....	36
Table 18 : Mapping table BMF / TV-A	39

List of Abbreviations

Acronym	Description
BMF	Broadcast Metadata Format
CRID	Content Ressource Identifier
CRUD	Create, read, update, delete
DVB	Digital Video Broadcasting
egta	Association of television and radio sales houses (fka European Group of Television Advertisers)
HTTP	Hypertext transfer protocol
JSON	JavaScript object notation
NIC	News item container
NIC-PSN format	News item container format for use case "Personalized Semantic News"
RDF	Resource Description Format
SOA	Service-oriented Architecture
TV-A	TV-Anytime
UML	Unified Modelling Language
XSLT	Extensible Stylesheet Language Transformations
YAML	YAML Ain't Markup Language

1. Introduction

As content for the NoTube platform may be provided by different sources, and may be lacking information required by the use cases, WP2 will provide services to satisfy these requirements. The analysis of the gathered requirements coming from the NoTube use cases can be split in three categories: *Metadata extraction*, *Metadata injection* and the *Metadata conversion*.

Corresponding to these different categories, WP2 will provide dedicated services. The first service will transform alien metadata into TV-Anytime (TV-A). The TV-Anytime format has been selected as internal persistence NoTube format for the Provider Side as well for the HomeAmbient Side. The second service will be used for *CRUD* (Create, Read, Update, Delete) operations, which correspond to the categories *Metadata extraction and Metadata injection*.

This deliverable presents the underlying components which are used for the TV metadata interoperability in NoTube, i.e. services that provide functionalities to convert metadata from input formats to TV-Anytime metadata and to provide *CRUD* functionalities to the just created or already existing TV-Anytime metadata.

Chapter 2 presents the requirements assessment from the use cases, while chapter 3 gives detailed information about the components for the metadata conversion. In chapter 4 the *CRUD* components are explained. Finally, chapter 5 will give an overview of the planned evaluation of the components. The conclusion can be found in chapter 6. The appendix provides mapping tables of the different conversions and also class diagrams of the specified software components.

In addition, Deliverable D2.3 presents the description of the corresponding web services.

2. Requirements

This chapter gives an overview about the re-assessment and the concretion of the requirements for the metadata exchange and the data formats related to the three use cases. The previous collected requirements have been updated respectively extended with regard to the deliverable 2.1 (version 2.0).

2.1. Re-assessment of requirements from use case 7a Personalized Semantic News

As described in deliverable 2.1 (version 2.0) for the use case "*Personalised Semantic News*" the essential role for the metadata exchange is played by the so called News Item Container (NIC). The NIC is defined as "the object which goes through the system and is enriched along the workflow" (see Deliverable of D7a.2). During the last project phase the characteristics of the NIC have been concretised and the adequate requirements collected. This work has been done in close collaboration with the work package 7a members.

The following tables show all elaborated and re-assessed requirements for the use case "Personalised Semantic News". The NIC is composed of different parts. At first you have the part that holds the generic information about the NIC itself. The second part is describing a set of specific information about the internal content (so called Attractor part). The third part holds one or more descriptions about contents, which includes the main content and the description of all directly or indirectly related contents. Furthermore the NIC contains the

description of the relationship between each related content and the main content (Facet part). Additionally there is some management information about the NIC.

Within the following table the metadata are listed to hold the generic information about the NIC.

Number	The metadata model should have the ability to:
2.1.1	Univocal ID for the NIC. (Identifier for the metadata instance)
2.1.2	NICType

Table 1 : NIC - Generic information

The description of the attractor part of the NIC is given as in the following table. In general the attractor part should be able to hold many different structures, which hold specific information about the content. Therefore the following requirements have to be interpreted as examples of a specific attractor.

Number	The metadata model should have the ability to:
2.1.3	Hold the title of a News Item
2.1.4	Describe the subject of a News Item
2.1.5	Describe the classification (genre) of a News Item (e.g. "Sports news", "Weather forecast")
2.1.6	Hold information about location covered by the News Item
2.1.7	Hold an abstract (synopsis) of the News Item
2.1.8	Hold person related data, such as forename, surname etc. This could be also a link to a suitable person description.

Table 2 : NIC – Attractor information

The NIC container could hold several descriptions for different content. To describe a content object the following metadata should be used.

Number	The metadata model should have the ability to:
2.1.9	Describe the type of the content (e.g. "video", "audio", "picture", "text") These information are contained in the so called <i>ContentInfo</i> structure of a NIC.
2.1.10	Hold information about the location covered by the content
2.1.11	Hold person related data, such as forename, surname etc. This could be also a link to a suitable person description.
2.1.12	Describe the role of a person (e.g. "creator", "anchorman", "subject") This could be also a link to a suitable role description.
2.1.13	Hold information about the language for audio, captions, subtitles
2.1.14	Describe timelines for video and audio
2.1.15	Assign descriptions to a specific timeline event for a specific duration
2.1.16	Hold information about (copy-, digital-)rights
2.1.17	Hold information about and to link to external referenced resources
2.1.18	Reference to the physical content
2.1.19	Hold and describe text content (e.g. text result from speech-to-text tool)
2.1.20	Hold relationships to derived content which is described in the same NIC (<i>Derivation</i>). There are four categories of derivations (<i>Transmoding, Transcoding, Summarization, Translation</i>), which have to be distinguished.
2.1.21	Hold relationships to related content (for equivalence of use criteria) which is described in the same NIC (<i>ShapeLayer</i>).
2.1.22	Hold relationships to related content (for representativeness criteria) which is described in the same NIC (<i>RepresentationLayer</i>).

Table 3 : NIC – Content description

The following table contains the needed information of the *Facet* part.

Number	The metadata model should have the ability to:
2.1.23	Description of the relationship between main and related content.
2.1.24	Link to the related content.
2.1.25	Identifier of the relationship.
2.1.26	Weight of the relationship.

Table 4 : NIC – Facet description

The metadata related to management purposes are listed below.

Number	The metadata model should have the ability to:
2.1.26	Owner of the NIC.
2.1.27	Creation time.
2.1.28	Last change time.

Table 5 : NIC – Management information

The TV-A format has been selected as internal NoTube format for the provider side as well as for the Home Ambient. Therefore the listed required information above were mapped into TV-A. For a further description of this mapping see chapter 3.

An essential requirement to support the specified features for the *Personalised Semantic News* use case is the *CRUD* functionality. This enables applications to retrieve and to manipulate NIC objects without knowing the internal TV-A NIC format. A description of the developed design for the *CRUD* functionality can be found in chapter 4.

2.2. Re-assessment of requirements from use case 7b Personalised EPG

The following tables show all elaborated and re-assessed requirements for the use case “*Personalised TV guide with Adaptive Advertising*” (7b).

In this use case, we need metadata to describe advertisements (ads). These metadata are essential to ensure that users have access to personalised content (i.e. according to their specific interests).

Number	Requirement: The metadata model should have the ability to:
2.2.1	Hold the title of the ad
2.2.2	Describe briefly the ad
2.2.3	Describe deeper the ad
2.2.4	Hold the ad genre
2.2.5	Hold the keywords that describes the ad
2.2.6	Hold the start time
2.2.7	Hold the end time
2.2.8	Hold the duration
2.2.9	Hold the credits list (One or more persons/companies related to the TV program (e.g. Creator/Director/Producer/ Actor/Actress)
2.2.10	Hold the resources list (One or more resources related to the ad (e.g. preview image, links to related websites)
2.2.11	

Table 6 : Requirements to metadata used by use case 7b – Content description

Technical metadata are essential to technical management of this content (Region Of interest algorithm, Sequence of interest algorithm, Loudness harmonization).

Number	Requirement: The metadata model should have the ability to:
2.2.12	Hold the information about the file (name/format, size)
2.2.13	Hold the Information about the audio used in the ad (e.g. codec, format, language)
2.2.14	Hold the information about the video used in the ad (e.g. codec, format, aspect ratio)
2.2.15	Hold the information about the captioning

Table 7 : Requirements to metadata used by use case 7b – Technical metadata

For ads, some more information like intended audience (defined by age, cultural/ethnic background, profession etc.) can be very useful to target the best advertisement to the correct consumer.

Number	Requirement: The metadata model should have the ability to:
2.2.16	Hold the general audience
2.2.17	Hold the age groups (children, age 4-7, ...)
2.2.18	Hold the social groups
2.2.19	Hold the occupational groups
2.2.20	Hold the other special interests
2.2.21	Hold the gender (for men, for women, for both)
2.2.22	Hold the geographical location (territory for which the programme is primarily intended)
2.2.23	Hold the education level
2.2.24	Hold the lifestyle stages (single, couple, divorced, family ..., retired)
2.2.25	Hold the income

Table 8 : Requirements to metadata used by use case 7b – Intended audience description

2.3. Re-assessment of requirements from use case 7c Internet TV in the social web

WP7c's requirements are significantly different from those of the other use case partners. For use case 7c currently three prototypes are developed by other technical work packages in NoTube:

- A linked-data browser for BBC archival content
- An application enabling real-time interaction with other people watching the same programme
- A social-network based EPG filter

The requirements coming from these prototypes are to be able to precisely identify programmes using resolvable URIs for them. The BBC already provides openly HTTP-accessible metadata for each of its programmes in various machine-processable formats (*RDF*, *JSON* and *YAML*). A further service connecting DVB CRIDS with these BBC HTTP URIs has been developed within the project.

There are no requirements for additional services on WP2 by WP7c. Due to that fact the development of any software components for use case 7c is not taking into account by WP2.

3. TV Metadata Conversion Components

The TV-Anytime (TV-A) format has been selected as internal NoTube metadata format. Therefore for use case 7a the input *PrestoSpace* data (holds the information of the NICs) are transformed to TV-A objects. In detail one *PrestoSpace* document contains multiple news item descriptions. For that reason each news item description inside one *PrestoSpace* document will be transformed into one TV-A document.

But in order to be future proof, a more generic approach has been implemented instead of a simple one-to-one mapping from *PrestoSpace* to TV-A. To enable other broadcasters or other content providers to connect to the NoTube platform, a uniform interface is needed. Therefore, the Broadcast Metadata Exchange Format (BMF) [3] was chosen by WP2 as interface between the NoTube platform and external broadcast sources.

The transformation process for use case 7a maps first the *PrestoSpace* data into BMF, which is described in chapter 3.1. The transformation BMF-to-TV-A is done in a second step (see chapter 3.2). This approach enables easily to add other metadata formats as input for the platform (e.g. *FESAD*, a widely used format by the German Public Service Broadcasters, or *NewsML*) at a later time. These different transformations are implemented as separate services and due to this fact the modular approach is supported. The specification of these services is described in deliverable D2.3 of WP2.

For use case 7b the *egtaMETA* format was selected as input for advertisement information. This format is also mapped into TV-A by another transformation, which is described in detail in chapter 3.3.

3.1. *PrestoSpace2Bmf*

The mapping between *PrestoSpace* and BMF has been developed taking into account the requirements from the use case 7a. The following chapter describes the conceptual mapping and the realized components for that transformation.

3.1.1. *Conceptual mapping*

The required data fields for the mapping between *PrestoSpace* and BMF were identified during the previous project phase. For these identified data fields of *PrestoSpace* and BMF the mapping relationships were specified and transferred into a mapping table. The mapping table is listed in annex C.

3.1.2. *Software components*

The *PrestoSpace2Bmf* component is responsible for the mapping from *PrestoSpace* metadata format, used as input format in use case 7a, to BMF metadata format. The component handles an XML input string and outputs valid BMF XML data after a successful transformation. For accessing, changing and creating XML nodes in *PrestoSpace* and BMF format, both metadata schemes were converted into a java class representation. Therefore *XMLBeans* [1] was used to generate these classes and the required interfaces. With the generated *PrestoSpace* and BMF *XMLBeans* Frameworks it is possible to de-serialize XML data into java objects and vice versa. The following UML class diagram gives an overview of the component structure.

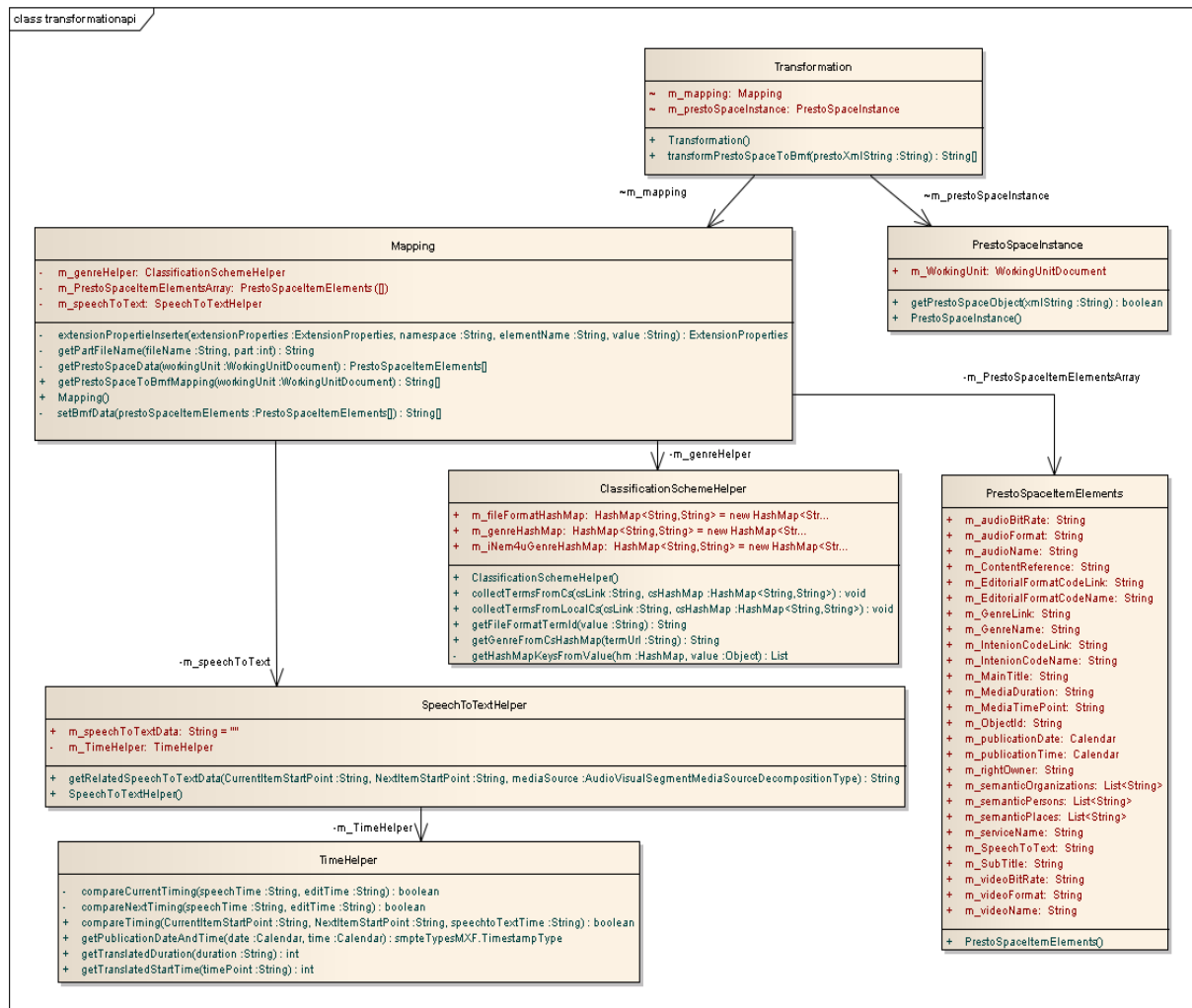

Figure 1 : Component structure for the *PrestoSpace* to BMF transformation

The *Transformation* class builds the interface of the component. By this class the component can be easily integrated into other external components, e. g. web service stub classes. The core of the component builds the *Mapping* class with its three main methods *getPrestoSpaceData*, *getPrestoSpaceToBmfMapping* and *setBmfData*.

- *getPrestoSpaceData*: extracts all relevant data from the input *PrestoSpace* XML instance. Due to the fact that the *PrestoSpace* input describes a complete program, it is necessary to extract all single items and program relevant data. An array of these items builds the output of the method.
- *setBmfData*: uses the output of *getPrestoSpaceData* as input. For each item the method generates the corresponding BMF item object and fills the element values with the data from *PrestoSpace*.
- *getPrestoSpaceToBmfMapping*: builds the logical combination of the previous methods

The *Mapping* class also uses different helper classes to validate, transform and hold extracted *PrestoSpace* input data.

- *ClassificationSchemeHelper*: is used to validate referenced classification schemes. Classification schemes are controlled vocabularies, containing list of genres, file formats, etc.
- *SpeechToTextHelper*: merges single speech-to-text fragments to one transcript, representing the spoken text in an item¹
- *TimeHelper*: Transforms different time formats

3.2. Bmf2Tva

The mapping between BMF and TV-A has been developed taking into account the requirements from the use case 7a. The following chapter describes the conceptual mapping and the realized components for that transformation.

3.2.1. Conceptual mapping

For the conceptual mapping between BMF and TV-A all required data fields were identified in each format. For the identified data fields of BMF and TV-A the mapping relationships were specified and transferred into a mapping table. This mapping table was the base for the implementation of the transformation and is listed in annex D.

3.2.2. Software components

The software module for the transformation from the BMF format to TV-A has been implemented as several components and follows to a modular approach. Thus an extension of the software can be done in a flexible way in the future. The implementation was done in the programming language Java, which enables a strict object oriented realization. Due to the fact that the metadata are transferred as XML documents the *XMLBeans [1]* library was integrated into the transformation module. This allows a computation of XML data as java objects.

For the transformation new software components were designed and implemented, but also already existing components were used to fit in the requirements in NoTube. During the European project *iNEM4U [2]*, in which the IRT was a technical partner, a generic API for metadata handling was developed. This API has been extended in the implementation phase in NoTube to compute BMF metadata and to translate it to TV-A.

The *Metadata-API* and the other components are described in the sections below. In Figure 2 an overview of the different implemented components is shown. This is an abstract visualization to get an impression of the functionality as a whole.

¹ This class is only used internally to compute the appropriate data fields inside the PrestoSpace document.

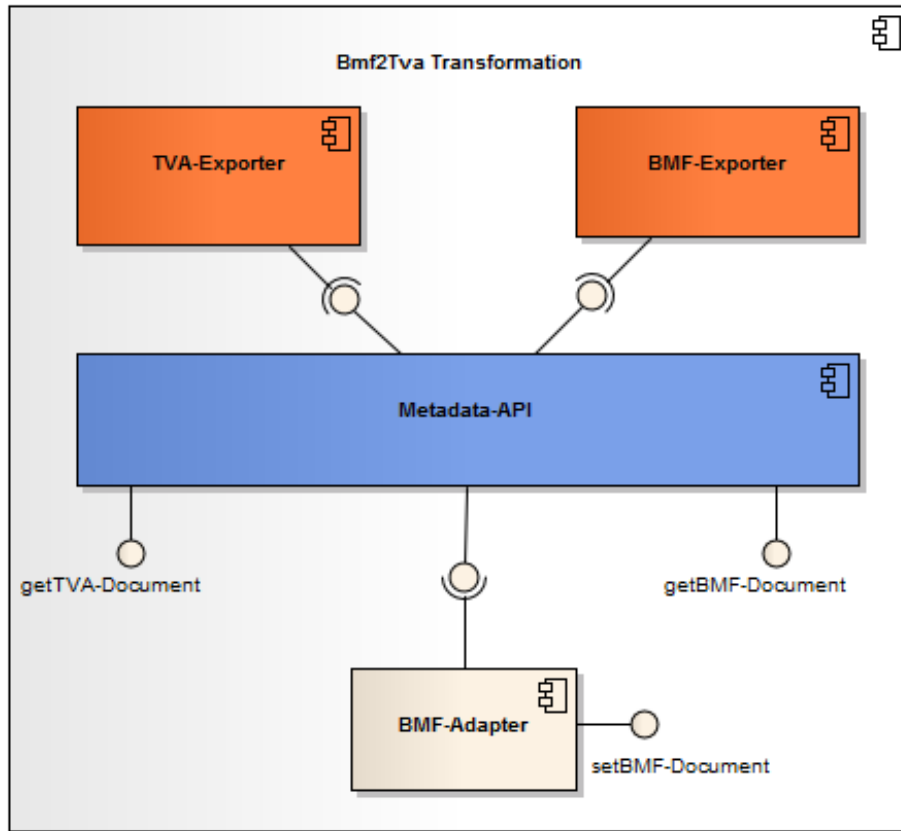

Figure 2 : Components for the BMF to TVA transformation

Metadata-API:

The *Metadata-API* is the central logic component for the transformation. It is able to compute different metadata input formats in a generic way. Therefore the component is using an abstract data format inside. All input formats have to be transferred to this abstract format. The *Metadata-API* component provides the interfaces to navigate on the metadata and to retrieve the data in another format.

BMF-Adapter:

This software component represents an adapter for BMF metadata. It transforms BMF data to the abstract data format inside the *Metadata-API*. The *BMF-Adapter* enables the handling of BMF input documents, which should be transformed into TV-A. For the implementation, especially for testing purposes, a set of BMF example documents has been created.

TVA-Exporter:

The *TVA-Exporter* is responsible for the export of the input metadata as TV-A documents. This software implements the transformation of the abstract data format, which is used inside the *Metadata-API*, into TV-A.

BMF-Exporter:

The possibility to retrieve the input data as BMF documents is implemented in the *BMF-Exporter* component. It implements the transformation of the abstract data format, which is used inside the *Metadata-API*, to BMF.

3.3. EGTA2TVAnytime component

The *EGTA2TVAnytime* component is responsible for the mapping from the *egtaMETA* format, used as input format in use case 7b, to TV-A metadata. The component handles an XML input string and gives, for output, a valid TV-A XML object after a successful transformation. BMF is not used as input interface here since *egtaMETA* is not a professional broadcast metadata format.

3.3.1. Conceptual mapping

For the conceptual mapping between *egtaMETA* and TV-A, all required data fields were identified in each format. For the identified data fields of *egtaMETA* and TV-A, the mapping relationships were specified and transferred into a mapping table and listed in appendix E.

3.3.2. Software component

The software module for the transformation from the *egtaMETA* format to TV-A has been implemented in one component. For the transformation from *egtaMETA* to TV-A, we use *XSLT* which is a language for transforming XML documents into to other XML documents.

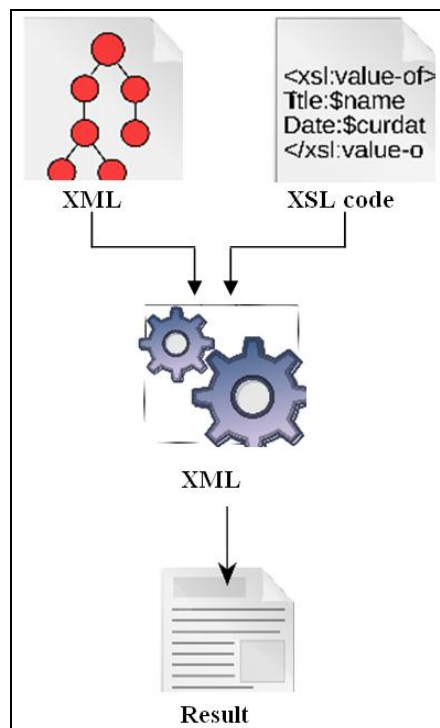

Figure 3 : XSLT-Process of the *EGTA2TVAnytime* component

With *XSLT*, it is possible to add/remove elements and attributes to or from the output file. *XSLT* uses *XPath* to find information in an XML document. *XPath* is used to navigate through elements and attributes in XML documents. In the transformation process, *XSLT* uses *XPath* to define parts of the source document that should match one or more predefined templates. When a match is found, *XSLT* will transform the matching part of the source document into the result document.

4. TV Metadata *CRUD* Components

The *CRUD* functionality on NIC objects is an essential requirement in NoTube; especially for the use case *7a Personalized Semantic News*. The *CRUD* components were designed and will be implemented to enable applications to retrieve and to manipulate news related data - the NIC objects. The component allows other applications to operate on NIC objects without knowing the internal NoTube format (TV-A). *CRUD* components provide the possibility to create, read, update and to delete specific data structures, which are part of the news information. For this required data handling appropriate interfaces and software components were specified. This work has been done in close cooperation with the members of use case *7a*.

4.1. *CRUD* architecture

The *CRUD* functionality is designed in two main components, which are described below. The NIC metadata is stored as TV-A documents. That means the requests and the manipulations will take place on that TV-A data. For this functional range the *TVA-CRUD component* is responsible.

The applications related to use case *7a* need the news item related information in a specific XML-based format (*NIC-PSN² format*). Due to that fact a second component - the *NIC-CRUD component* - was specified to provide the *CRUD* possibilities based on that specific *NIC-PSN format*. Furthermore this *NIC-CRUD component* is using the *TVA-CRUD component* to get access to the TV-A documents. An overview of the *CRUD* architecture is shown in Figure 4.

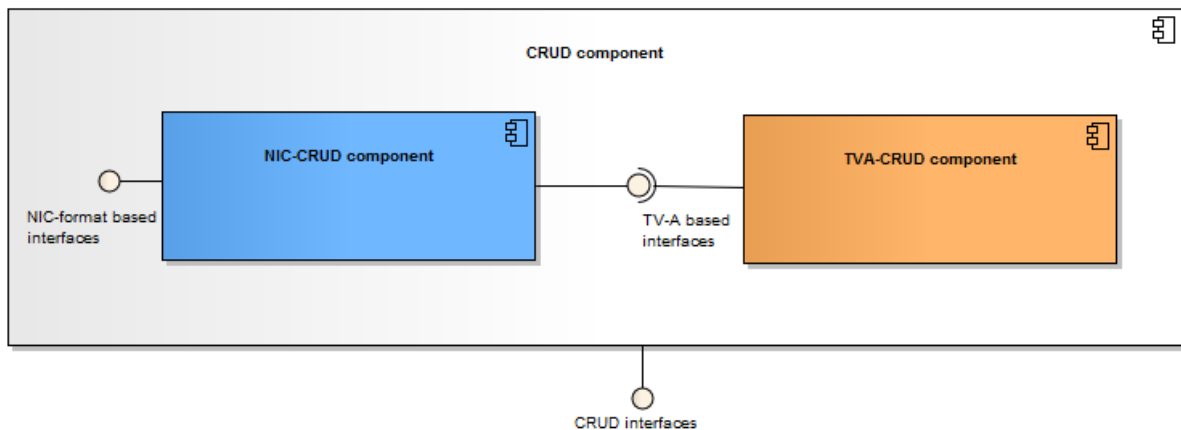

Figure 4 : Overview *CRUD* architecture

For the integration in the NoTube infrastructure and to follow the SOA based approach a service was specified to provide all *CRUD* functionalities. This service will use the mentioned components above. The definition for that service can be found in deliverable D2.3 of WP2.

The interfaces of the *TVA-CRUD* and the *NIC-CRUD components* are concrete realisations of the generic specified *CRUD* interfaces, which are described in the following chapter.

² Personalized Semantic News

4.2. CRUD Interfaces

The interfaces of the *CRUD* component are designed based on the evaluated metadata requirements for use case 7a (see chapter 2.1). The *CRUD* functions are also described in deliverable D7a.3.

The concept of the *NIC* defines different parts to describe information about news. For each of these different parts respectively for these different data structures the *CRUD* component provides appropriate interfaces to create, read, update and delete them.

In the following tables the interfaces are described in a generic way related to the different parts of the *NIC* concept. The concrete implementation of these interfaces will be done in the two main components. The difference between them is the data format which is used for the parameter. The *TVA-CRUD component* is using TV-A based parameters and the *NIC-CRUD component* is using the *NIC-PSN format*. The appropriate interfaces of the two main components are described in the chapters 4.3 and 4.4.

The *NIC* container could hold several descriptions for different content (main content, related content). The main content represents the news item and the other contents are related to that news. To work on the appropriate data fields the following interfaces are requested.

NIC – Content	
Interface	Description
<i>Get_MainContent</i>	Retrieves the main content.
<i>UpDate_MainContent</i>	Updates the main content.
<i>Add_RelatedContent</i>	Adds a new related content to the <i>NIC</i> .
<i>Get_RelatedContent</i>	Retrieves a specific related content of the <i>NIC</i> .
<i>UpDate_RelatedContent</i>	Updates the specified related content.
<i>Remove_RelatedContent</i>	Deletes the specified related content.
<i>Get_Content</i>	Generic interface to retrieve a specified content description.
<i>Update_Content</i>	Generic interface to update a specified content description.

Table 9 : Interfaces for the NIC – Content

The *ContentInfo* structure describes the technical (physical) properties of the content. The following table lists the needed interfaces.

NIC – ContentInfo³	
Interface	Description
<i>Add_ContentInfoSet</i>	Adds a new <i>ContentInfoSet</i> to <i>NIC</i> .
<i>Get_ContentInfoSet</i>	Retrieves a specific <i>ContentInfoSet</i> of the <i>NIC</i> .
<i>Get_ContentInfoSet_by_Name</i>	Retrieves a <i>ContentInfoSet</i> with the specified name.
<i>UpDate_ContentInfoSet</i>	Updates the specified <i>ContentInfoSet</i> .
<i>Remove_ContentInfoSet</i>	Deletes the specified <i>ContentInfoSet</i> .

Table 10 : Interfaces for the NIC – ContentInfo

³ Contains technical information about the content.

The *Attractors* can hold different information about different contents (e.g. title, subject, classification). Table 11 contains the interfaces to retrieve and to manipulate the *Attractor* information.

NIC – Attractor	
Interface	Description
<i>Add_AttractorsSet</i>	Adds a new <i>AttractorSet</i> to NIC.
<i>Get_AttractorsSets</i>	Retrieves a list containing all <i>AttractorsSets</i> of the NIC.
<i>Get_AttractorsSet_by_Name</i>	Retrieves an <i>AttractorsSet</i> with a specified name.
<i>UpDate_AttractorsSet</i>	Updates the specified <i>AttractorsSet</i> .
<i>Remove_AttractorsSet</i>	Deletes the specified <i>AttractorsSet</i> .

Table 11 : Interfaces for the NIC – *Attractors*

The NIC contains the description of the relationship between each related content and the main content. This part is called *Facet* and the required interfaces are shown in the table below.

NIC – Facets⁴	
Interface	Description
<i>Add_Facet</i>	Adds a new <i>Facet</i> to NIC.
<i>Get_Facet</i>	Retrieves a specific <i>Facet</i> of the NIC.
<i>Get_Facet_by_Name</i>	Retrieves a <i>Facet</i> with a specified name.
<i>UpDate_Facet</i>	Updates the specified <i>Facet</i> .
<i>Remove_Facet</i>	Deletes the specified <i>Facet</i> .

Table 12 : Interfaces for the NIC – *Facets*

Inside the NIC a content description can have a derivation with a specific type. These derivation types are: Transmoding, Transcoding, Translation, and Summarization. To work on these derivation data the following interfaces are needed.

NIC – Derivation	
Interface	Description
<i>Add_Derivation</i>	Adds a new <i>Derivation</i> of a specified content to the NIC.
<i>Get_Derivation</i>	Retrieves a specific <i>Derivation</i> of a specified content. Which derivation (<i>Transmoding</i> , <i>Transcoding</i> , <i>Translation</i> , and <i>Summarization</i>) should be retrieved is specified by a parameter. If no parameter for the type of derivation is specified, all available derivations of the content will be retrieved.
<i>UpDate_Derivation</i>	Updates the specified <i>Derivation</i> .
<i>Remove_Derivation</i>	Deletes the specified <i>Derivation</i> .

Table 13 : Interfaces for the NIC – *Derivation*

The *ShapeLayer* describes the relations between the main content and other contents i.e. how the other contents can be used instead of the main content. The required interfaces are listed in the following table.

⁴ The concept of the *Facets* is described in chapter 2.1.

NIC – ShapeLayer	
Interface	Description
<i>Add_ShapeLayer</i>	Adds a new <i>ShapeLayer</i> to a specified content.
<i>Get_ShapeLayer</i>	Retrieves a specific <i>ShapeLayer</i> of a specified content.
<i>Get_ShapeLayer_by_Name</i>	Retrieves a <i>ShapeLayer</i> with a specified name.
<i>UpDate_ShapeLayer</i>	Updates the specified <i>ShapeLayer</i> .
<i>Remove_ShapeLayer</i>	Deletes the specified <i>ShapeLayer</i> .

Table 14 : Interfaces for the NIC – ShapeLayer

The *RepresentationLayer* describes the relations between the main content and other contents i.e. how the other content can be used to represent the main content. The interfaces for working on this data are listed below.

NIC – RepresentationLayer	
Interface	Description
<i>Add_RepresentationLayer</i>	Adds a new <i>RepresentationLayer</i> to a specified content.
<i>Get_RepresentationLayer</i>	Retrieves a specific <i>RepresentationLayer</i> of a specified content.
<i>Get_RepresentationLayer_by_Name</i>	Retrieves a <i>RepresentationLayer</i> with a specified name.
<i>UpDate_RepresentationLayer</i>	Updates the specified <i>RepresentationLayer</i> .
<i>Remove_RepresentationLayer</i>	Deletes the specified <i>RepresentationLayer</i> .

Table 15 : Interfaces for the NIC – RepresentationLayer

The management part of a NIC holds information about the identification, the type, the owner as well the publisher of a NIC. In Table 16 the requested interfaces to work on these data are displayed.

NIC – Management	
Interface	Description
<i>Create_NIC</i>	Creates a new NIC instance.
<i>Modify_NIC_Owner</i>	Updates the owner of the NIC.
<i>Get_NIC_Header</i>	Retrieves the header information of the NIC.
<i>Modify_NIC_Header</i>	Updates the header information of the NIC.
<i>Get_Management_Info</i>	Retrieves the management information of the NIC.

Table 16 : Interfaces for the NIC – Management

4.3. TVA-CRUD component

The *TVA-CRUD component* is a TV-A based implementation of the *CRUD* interface definition specified by use case 7a. The component contains an interface that implements the required *CRUD* operations to create, read, update and delete objects inside a NIC in the TV-A metadata format. An overview of the interfaces can be found in the UML class diagram in the appendix A.1.

By this approach of implementing a *CRUD* component handling metadata in TV-A format apart from the *NIC-PSN format*, it is possible for other project partners to directly manipulate TV-A NICs in TV-A format if necessary.

The component consists of concrete classes and generic helper classes. The concrete classes are implementing the *CRUD* functionalities grouped by the corresponding NIC set functionalities, like *Attractors*, *ContentInfo*, *Shapes* or *Representations* sets. The generic helper classes are used to retrieve any TV-A object from or write any TV-A object to a TV-A-NIC. For reading TV-A objects the *TvaAccessor* could be used by any concrete class. The *TvaManipulator* is responsible for writing or removing given TV-A-Objects to or from a TV-A-NIC. The class architecture of the *TVA-CRUD* component can be found in annex A.2

4.4. *NIC-CRUD component*

The specification of the *NIC-CRUD* component is based on the XML-based *NIC-PSN format* that has been specified by use case 7a. It provides the *CRUD* functionality by appropriate interfaces, which are parameterized by the data structures of the *NIC-PSN format*.

The *NIC-CRUD* component has internally different helper classes, which have different responsibilities. The *NicAccessor* helper class is designed to read the requested data from a NIC-object. For writing and removing data objects to or from a NIC-object the *NicManipulator* is responsible.

Due to the fact that the information about a NIC is stored as a TV-A document the *NIC-CRUD component* must be also able to handle the TV-A data structures internally. It delegates the requested *CRUD* functionality to the *TVA-CRUD* component (see chapter 4.3) that is working on TV-A documents. Therefore the *NIC-CRUD* component has to transform bi-directional TV-A data objects to appropriate objects in the *NIC-PSN format*.

An overview of the interfaces of the *NIC-CRUD component* can be found in the UML class diagram in the appendix B.

5. Evaluation

This chapter describes how the work of WP2 will be evaluated. The evaluation process can be divided in two main parts: the technical and the user evaluation. During the technical inspections, the actual work of the mappings and translations is under test, while the user tests will be done with the complete NoTube applications.

5.1. Technical Evaluation

The technical evaluation of WP2 will focus on the evaluation of the data quality in the metadata transformation process. Evaluating data quality of a metadata translation usually consists of multiple steps. The first step is to identify the elements in the source format to be mapped. This can be the complete instance or just a subset of elements from a (large) instance. The second step is to actually map the identified elements to the target format and inspect the created instance for all required elements to be present.

5.1.1. Evaluation for use case 7a

To evaluate the data quality of use case 7a, it is planned to do a manual comparison between two metadata instances. The first is a *PrestoSpace* instance provided by RAI which contains the maximum set of required data in the incoming data to be mapped. This instance will be used as input for the conversion service and transformed to TV-A. This conversion will create the second instance (now in the NoTube format) for the comparison.

To check if all information is transparently mapped and the data is preserved, input and output instance are then compared with respect to the initially defined required elements in the *PrestoSpace* instance.

5.1.2. Evaluation for use case 7b

To evaluate the data quality of use case 7b, a manual comparison between an *egtaMETA* instance and the resulting TV-A instance will be performed. This comparison will allow identifying:

- Unnecessary data
- Missing data
- Coherence errors in the transformation

5.2. User Evaluation

For the user evaluation in the second evaluation phase of NoTube, the technical functionalities developed in WP2 will be provided according to the requirements from the NoTube use cases. There are no requirements from WP2 regarding a dedicated user evaluation of technologies developed within this work package since there will be no direct interaction of the user with the functionalities provided by WP2.

6. Conclusion

WP2 has done a re-assessment of requirements for metadata transformations and metadata computation regarding the three use cases in NoTube. As internal metadata format for the Server Provider side as well for the Home Ambient side the TV-Anytime format has been selected, which fulfils the requirements. Due to that fact the specified and implemented transformation components are focussed on TV-A.

For the use case *7a Personalized Semantic News* the mapping between *PrestoSpace* and the selected internal persistent NoTube format – the TV-A format – has been developed and implemented in several software components. In order to be future proof, the Broadcast Metadata Exchange Format (*BMF*) has been chosen as interface between the NoTube platform and external broadcast sources. Therefore the mapping process is done in two steps. First the transformation from *PrestoSpace* to *BMF* and in a second step the transformation from *BMF* to TV-A. These two transformations are implemented as separate software modules which are used by appropriate services inside the NoTube platform.

The specified component that provides the *CRUD* functionality on the news item related information (*NIC* objects) fulfils an essential requirement in NoTube, especially for use case *7a*. It will enable applications to create, read, update and to delete news related data structures. The specification has been done in close cooperation with members of use case *7a*. The *CRUD* functionality is specified in two separate components. The *TVA-CRUD* component is based on the TV-A format and the *NIC-CRUD* component is using the specific xml-based *NIC-PSN format* that is required by use case *7a* applications. The implementation of these *CRUD* components will be finished in Q1 2011.

As professional input format for advertisement description the *egtaMETA* format has been selected for the use case *7b Personalized TV Guide with Adaptive Advertising*. To transfer this advertisement information into the internal NoTube format the mapping between *egtaMETA* and TV-A has been specified and implemented in an appropriate software component. This component is intended to be used by a service to integrate the transformation inside the NoTube platform.

The technical evaluation for the different developed software components has been specified and described in this deliverable. It is an essential issue to ensure the quality regarding the data consistency and data privacy aspects which have to be evaluated. This evaluation will take place in the first months of 2011. During the evaluation and testing phase further requirements will be collected, if necessary, and will be used for the next iteration of implementation.

All implemented software components follow a modular design approach that enables a flexible extension and integration in the system architecture. The developed components for the metadata translation and the *CRUD* functionality are the base for the metadata (TV and advertisement) interoperability in NoTube. The specifications for the appropriate services, which are using the mentioned components, are described in deliverable D2.3 of WP2. These services will be integrated into the SOA-based NoTube system architecture.

References

- [1] <http://xmlbeans.apache.org/index.html>
- [2] <http://www.inem4u.eu/>
- [3] <http://www.irt.de/bmf>

Appendix

A TVA-CRUD component

A.1 TVA-CRUD interfaces

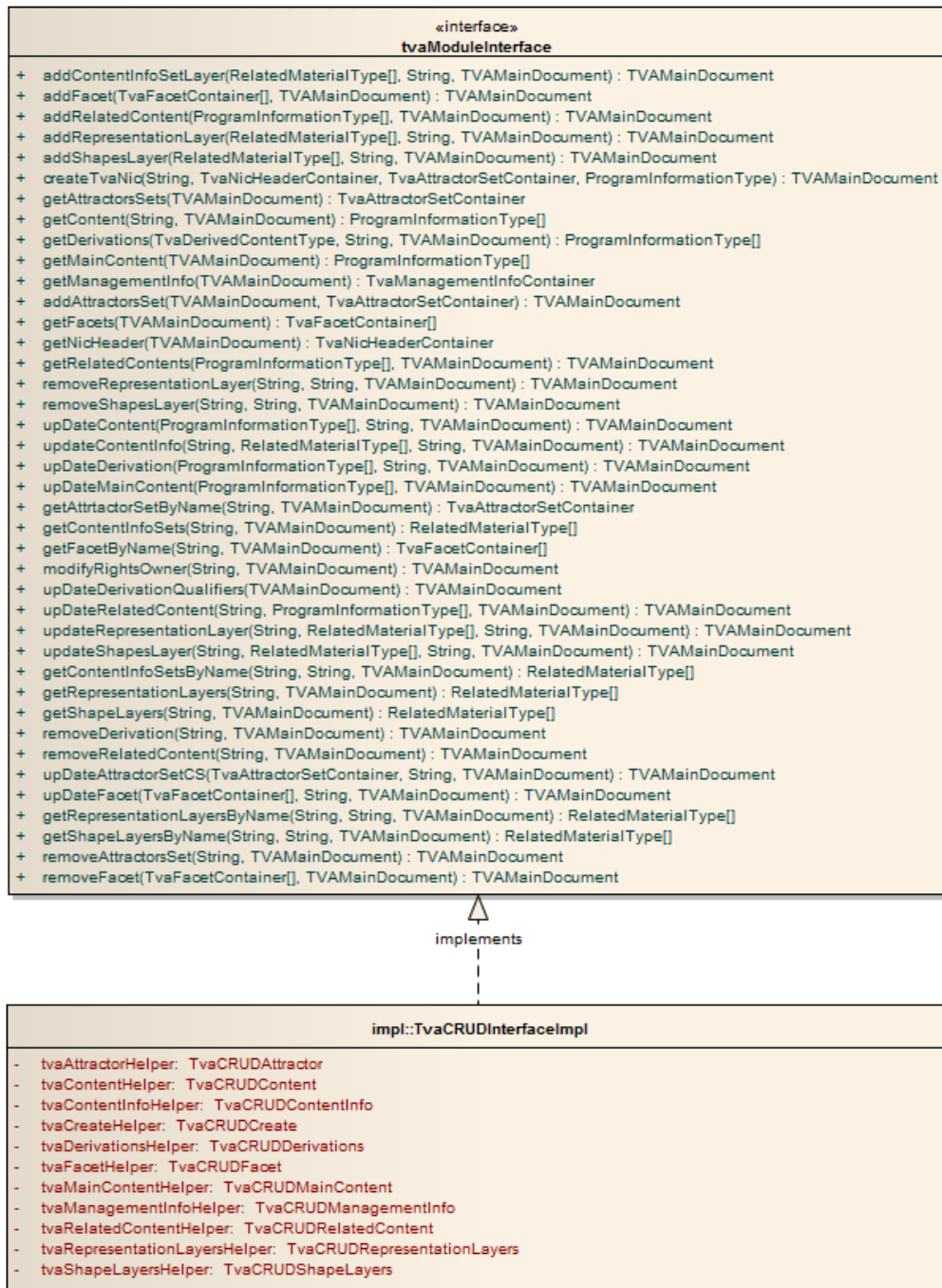

Figure 5 : TVA-CRUD component interfaces

A.2 TVA-CRUD class diagrams

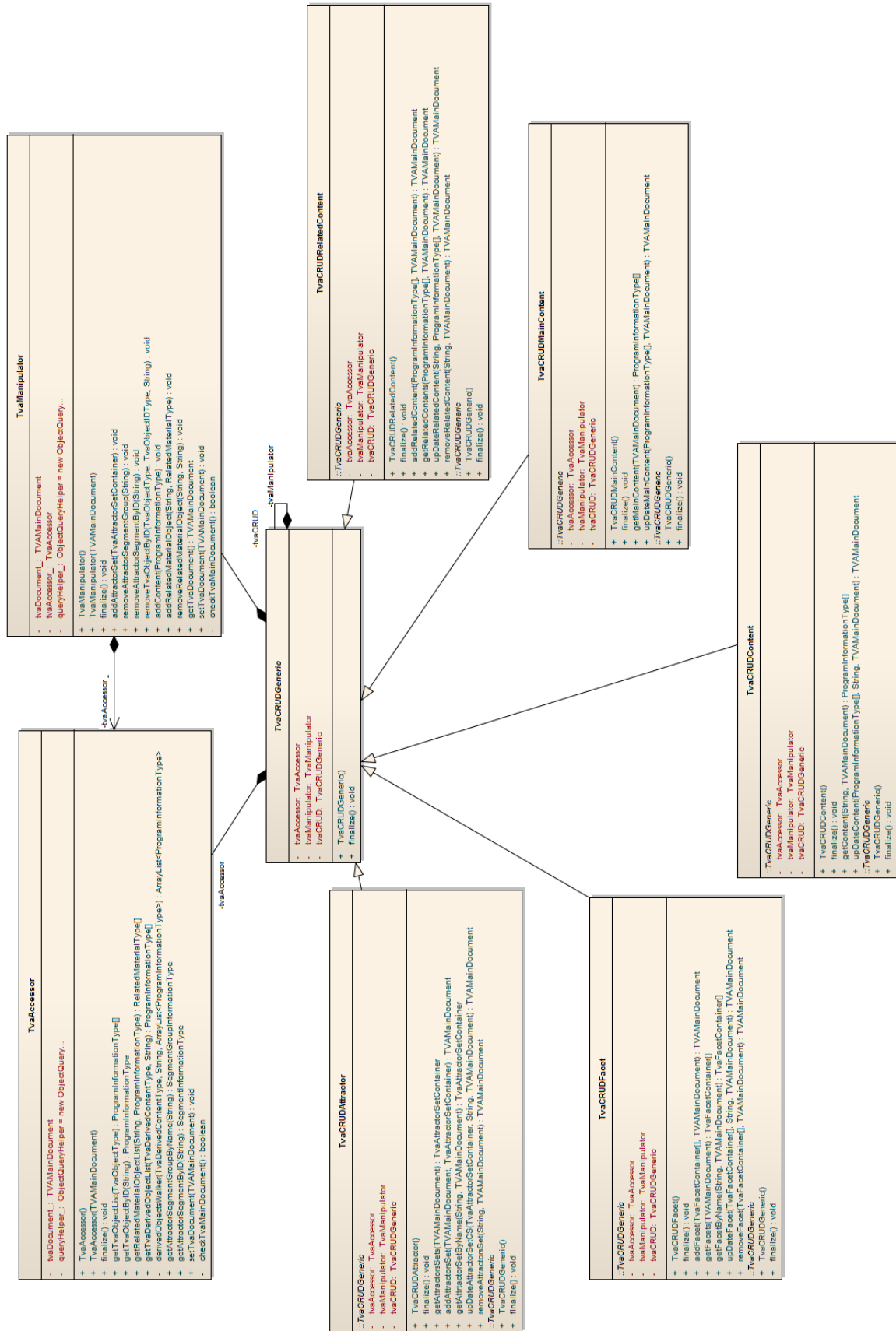

Figure 6 : TVA-CRUD component class diagram 1

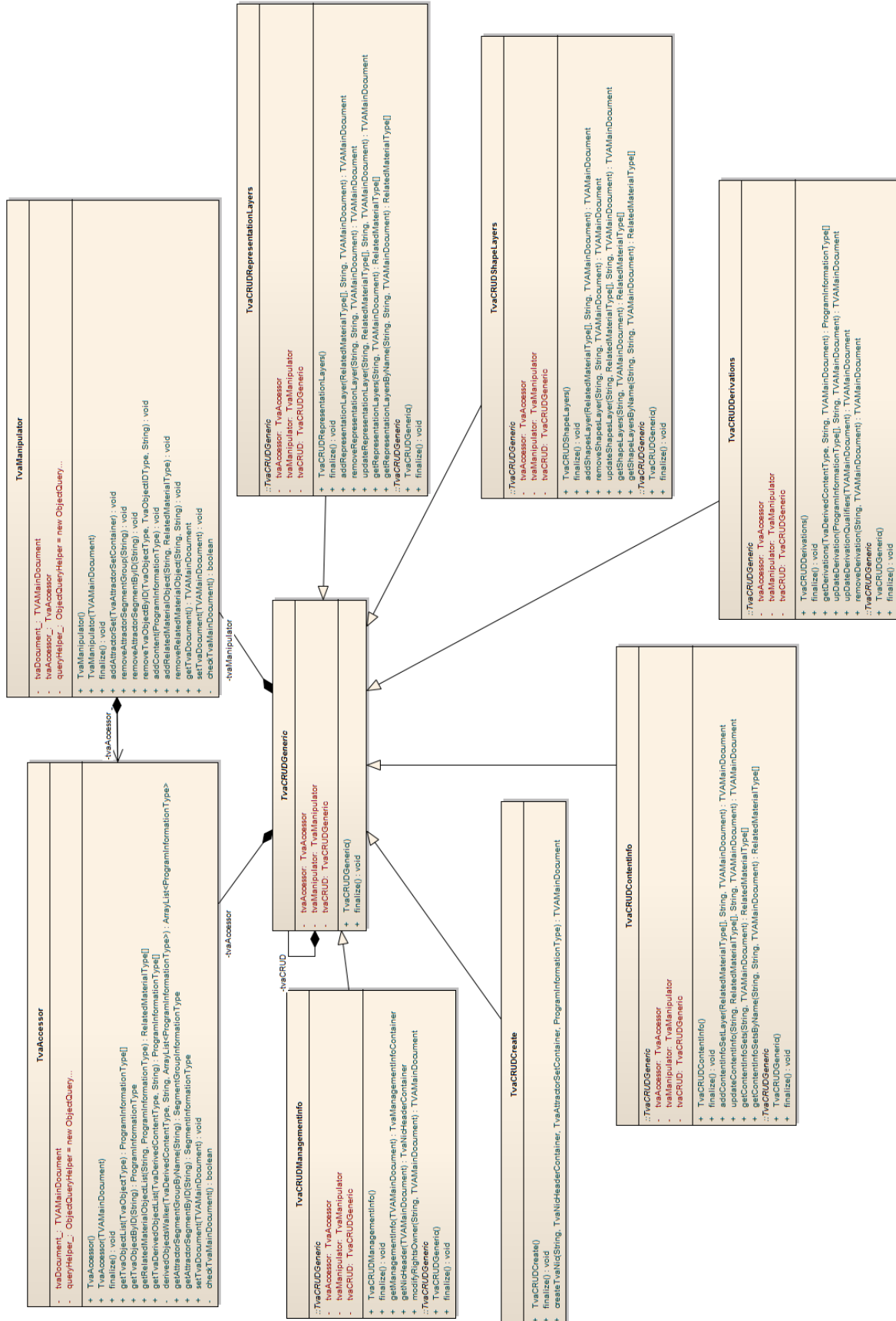

Figure 7 : TVA-CRUD component class diagram 2

B NIC-CRUD component

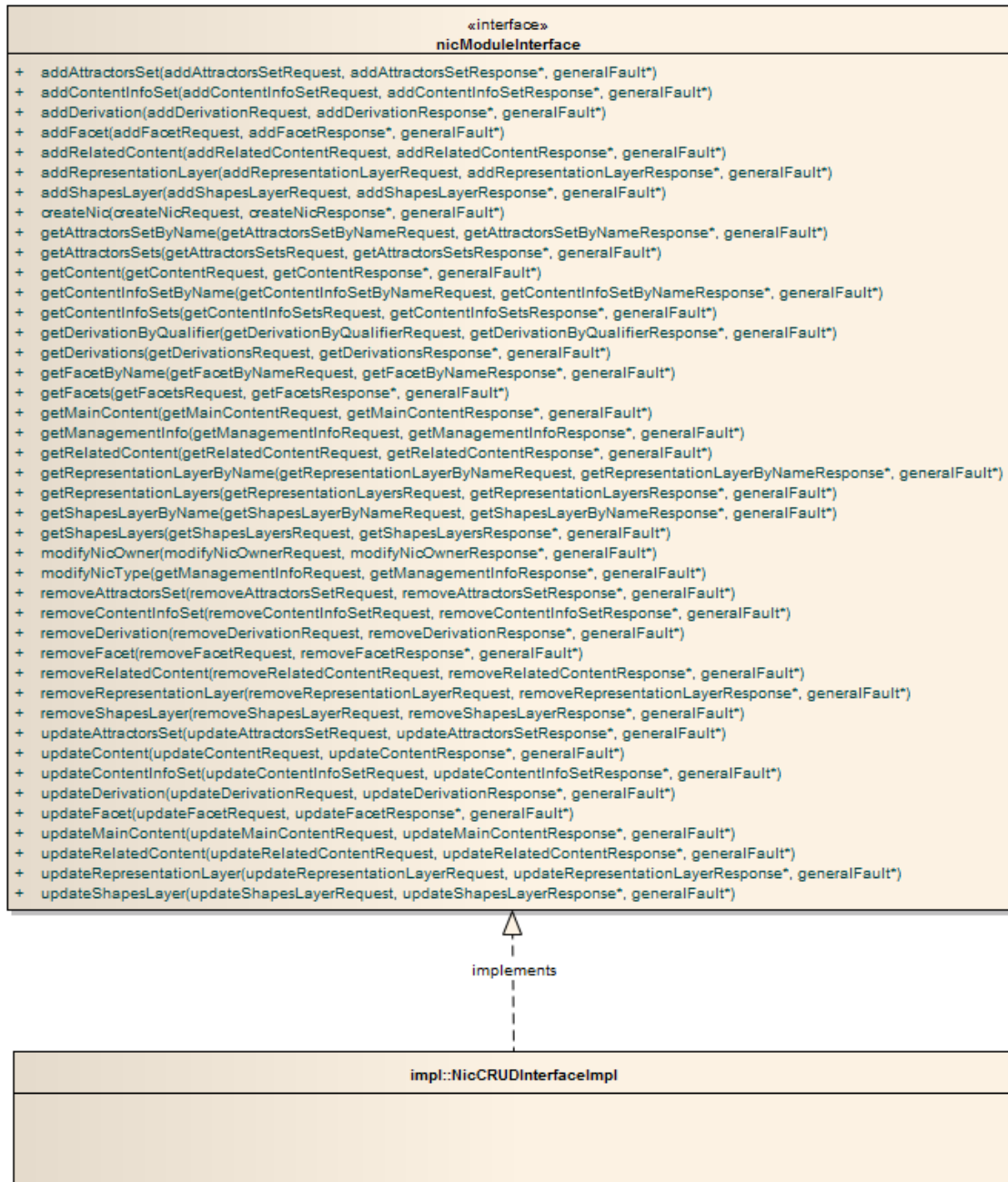

Figure 8 : NIC-CRUD component interfaces

C PrestoSpace / BMF Mapping Table

PrestoSpace	BMF	Description	PrestoSpace Element Path	BMF Element Path
ProgrammeTitle	MainTitle	The main title of the program	/wu:WorkingUnit/EditorialObject/Titles/pmeta:ProgrammeTitleHistory/pmeta:OriginalProgrammeTitle/pmeta:ProgrammeTitle	/BmfDatastructure:Datastructure/Bmf:BMFItem/BmfDict:MasterItem/BmfProgrammes:Item/rp210Elements:MainTitle
ProgrammeSubtitle	SecondaryTitle	The second title of the program	/wu:WorkingUnit/EditorialObject/Titles/pmeta:ProgrammeTitleHistory/pmeta:OriginalProgrammeTitle/pmeta:ProgrammeSubtitle	/BmfDatastructure:Datastructure/Bmf:BMFItem/BmfDict:MasterItem/BmfProgrammes:Item/rp210Elements:SecondaryTitle
ClassificationTerm Name	RealisationFocus:Element	The primary apparent intention in transmitting the programme	/wu:WorkingUnit/EditorialObject/OriginalClassification/pmeta:ClassificationIndex/pmeta:ClassificationData[1]/pmeta:ClassificationTerm/pmeta:ClassificationTermName	/BmfDatastructure:Datastructure/Bmf:BMFItem/BmfDict:MasterItem/BmfProgrammes:Item/BmfDict:Classification/BmfAnnotation:NonFictionalPresentationForm/BmfDict:RealisationFocus/BmfTypes:Element
ClassificationTerm Code	RealisationFocus:thesaurusID	Classification Scheme Reference	/wu:WorkingUnit/EditorialObject/OriginalClassification/pmeta:ClassificationIndex/pmeta:ClassificationData[1]/pmeta:ClassificationTerm/pmeta:ClassificationTermCode	/BmfDatastructure:Datastructure/Bmf:BMFItem/BmfDict:MasterItem/BmfProgrammes:Item/BmfDict:Classification/BmfAnnotation:NonFictionalPresentationForm/BmfDict:RealisationFocus/BmfTypes:thesaurusID
ClassificationTerm Name	NonFictionalPresentationFormType:Element	This dimension is used to classify programmes as to their formal structure	/wu:WorkingUnit/EditorialObject/OriginalClassification/pmeta:ClassificationIndex/pmeta:ClassificationData[2]/pmeta:ClassificationTerm/pmeta:ClassificationTermName	/BmfDatastructure:Datastructure/Bmf:BMFItem/BmfDict:MasterItem/BmfProgrammes:Item/BmfDict:Classification/BmfAnnotation:NonFictionalPresentationForm/BmfDict:NonFictionalPresentationFormType/BmfTypes:Element
ClassificationTerm Code	NonFictionalPresentationFormType:thesaurusID	Classification Scheme Reference	/wu:WorkingUnit/EditorialObject/OriginalClassification/pmeta:ClassificationIndex/pmeta:ClassificationData[2]/pmeta:ClassificationTerm/pmeta:ClassificationTermCode	/BmfDatastructure:Datastructure/Bmf:BMFItem/BmfDict:MasterItem/BmfProgrammes:Item/BmfDict:Classification/BmfAnnotation:NonFictionalPresentationForm/BmfDict:NonFictionalPresentationFormType/BmfTypes:thesaurusID
Genre:href	NonFictionalPresentationGenreBatch:Element:Element	The genre of the item	/wu:WorkingUnit/EditorialObject/TimelineDecompositions/mp7:Mpeg7/mp7:Description/mp7:MultimediaContent/mp7:AudioVisual/mp7:TemporalDecomposition[2]/mp7:AudioVisualSegment[1]/mp7:CreationInformation/mp7:Classification/mp7:Genre[1]/@href	/BmfDatastructure:Datastructure/Bmf:BMFItem/BmfDict:MasterItem/BmfProgrammes:Item/BmfDict:Classification/BmfAnnotation:NonFictionalPresentationForm/BmfDict:NonFictionalPresentationGenreBatch/BmfDict:Element/BmfTypes:Element
	NonFictionalPresentationGenreBatch:Element:thesaurusID	Classification Scheme Reference		/BmfDatastructure:Datastructure/Bmf:BMFItem/BmfDict:MasterItem/BmfProgrammes:Item/BmfDict:Classification/BmfAnnotation:NonFictionalPresentationForm/BmfDict:NonFictionalPresentationGenreBatch/BmfDict:Element/BmfTypes:thesaurusID
MediaTimePoint	ItemEditorialSourceReferenceShot:StartPosition	The start position of the item in the program	/wu:WorkingUnit/EditorialObject/TimelineDecompositions/mp7:Mpeg7/mp7:Description/mp7:MultimediaContent/mp7:AudioVisual/mp7:TemporalDecomposition[2]/mp7:AudioVisualSegment[1]/mp7:MediaTime/mp7:MediaTimePoint	/BmfDatastructure:Datastructure/Bmf:BMFItem/BmfDict:MasterItem/BmfProgrammes:Item/BmfDict:ItemTrackArray/BmfProgrammes:ItemEditorialTrack/BmfDict:ItemEditorialSourceReferenceArray/BmfProgrammes:ItemEditorialSourceReferenceShot/rp210Elements:StartPosition
MediaDuration	ItemEditorialSourceReferenceShot:Duration	The duration of the item	/wu:WorkingUnit/EditorialObject/TimelineDecompositions/mp7:Mpeg7/mp7:Description/mp7:MultimediaContent/mp7:AudioVisual/mp7:TemporalDecomposition[2]/mp7:AudioVisualSegment[1]/mp7:MediaTime/mp7:MediaDuration	/BmfDatastructure:Datastructure/Bmf:BMFItem/BmfDict:MasterItem/BmfProgrammes:Item/BmfDict:ItemTrackArray/BmfProgrammes:ItemEditorialTrack/BmfDict:ItemEditorialSourceReferenceArray/BmfProgrammes:ItemEditorialSourceReferenceShot/rp210Elements:Duration
FirstPublicationEventStart:Date	PublicationStartDateandTime	Publication date and time of the program	/wu:WorkingUnit/EditorialObject/Publications/PublicationDetails/pmeta:PublicationDetails/pmeta:FirstPublicationEventStart/pmeta:Date	/BmfDatastructure:Datastructure/Bmf:BMFItem/BmfDict:MasterItem/BmfProgrammes:Item/BmfDict:PublicationBatch/BmfPublishing:Broadcast/BmfDict:PublicationStartDateandTime
FirstPublicationEventStart:Time			/wu:WorkingUnit/EditorialObject/Publications/PublicationDetails/pmeta:PublicationDetails/pmeta:FirstPublicationEventStart/pmeta:Time	
FreeTextAnnotation	ScriptingText	Transcript of the spoken text in the audio of the item	/wu:WorkingUnit/EditorialObject/TimelineDecompositions/mp7:Mpeg7/mp7:Description/mp7:MultimediaContent/mp7:AudioVisual/mp7:MediaSourceDecomposition/mp7:AudioSegment/mp7:TemporalDecomposition[1]/mp7:AudioSegment[1]/mp7:TemporalDecomposition/mp7:AudioSegment[1]/mp7:TextAnnotation/mp7:FreeTextAnnotation	/BmfDatastructure:Datastructure/Bmf:BMFItem/BmfDict:MasterItem/BmfProgrammes:Item/BmfDict:ScriptBatch/BmfProgrammes:Script/rp210Elements:ScriptingText

EditorialObject@id	ExternalProductionIdentifierBatch:Element	Identifier for the item	/wu:WorkingUnit/EditorialObject/TimelineDecompositions/mp7:Mpeg7/mp7:Description/mp7:MultimediaContent/mp7:AudioVisual/mp7:TemporalDecomposition[2]/mp7:AudioVisualSegment[1]/mp7:Header/EditorialObject/@id	/BmfDatastructure:Datastructure/Bmf:BMFItem/BmfDict:MasterItem/BmfProgrammes:Item/BmfDict:ExternalProductionIdentifierBatch/BmfDict:Element
OrganisationName	RightsHolder:Organisation_WEAKREF	Owner of the content right	/wu:WorkingUnit/EditorialObject/Publications/PublicationDetails/pmeta:PublicationDetails/pmeta:PublicationEventTransmissionService/pmeta:OrganisationName	/BmfDatastructure:Datastructure/Bmf:BMFItem/BmfDict:MasterItem/BmfProgrammes:Item/BmfDict:RightsBatch/BmfProgrammes:AvailableRights/BmfDict:RightsHolder/BmfProgrammes:Organisation_WEAKREF
ServiceName	ChannelName	The name of the channel/service the program is broadcasted in	/wu:WorkingUnit/EditorialObject/Publications/PublicationDetails/pmeta:PublicationDetails/pmeta:PublicationEventTransmissionService/pmeta:ServiceName	/BmfDatastructure:Datastructure/Bmf:BMFItem/BmfDict:MasterItem/BmfProgrammes:Item/BmfDict:PublicationBatch/BmfPublishing:Broadcast/BmfDict:ChannelName
mp7:SemanticPlaceType	LocationKind	Semantic places captured from the video/ speech to text transcript	/wu:WorkingUnit/EditorialObject/TimelineDecompositions/mp7:Mpeg7/mp7:Description/mp7:MultimediaContent/mp7:AudioVisual/mp7:TemporalDecomposition[2]/mp7:AudioVisualSegment[1]/mp7:Semantic/mp7:SemanticBase[1]/@xsi:type	/BmfDatastructure:Datastructure/Bmf:BMFItem/BmfDict:MasterItem/BmfProgrammes:Item/BmfDict:LocationBatch/BmfProgrammes:Location/BmfDict:LocationKind
Name	LocationDescription	Name of the semantic place	/wu:WorkingUnit/EditorialObject/TimelineDecompositions/mp7:Mpeg7/mp7:Description/mp7:MultimediaContent/mp7:AudioVisual/mp7:TemporalDecomposition[2]/mp7:AudioVisualSegment[1]/mp7:Semantic/mp7:SemanticBase[1]/mp7:Label/mp7:Name	/BmfDatastructure:Datastructure/Bmf:BMFItem/BmfDict:MasterItem/BmfProgrammes:Item/BmfDict:LocationBatch/BmfProgrammes:Location/rp210Elements:LocationDescription
mp7:OrganizationType	OthersFunction	Semantic organizations captured from the video/ speech to text transcript	/wu:WorkingUnit/EditorialObject/TimelineDecompositions/mp7:Mpeg7/mp7:Description/mp7:MultimediaContent/mp7:AudioVisual/mp7:TemporalDecomposition[2]/mp7:AudioVisualSegment[1]/mp7:Semantic/mp7:SemanticBase[2]/mp7:Agent/@xsi:type	/BmfDatastructure:Datastructure/Bmf:BMFItem/BmfDict:MasterItem/BmfProgrammes:Item/BmfDict:ParticipantOfProductionElementBatch/BmfProgrammes:Others[1]/BmfDict:OthersFunction
Name	LegalPerson:Organisation_WEAKREF	name of the semantic organization	/wu:WorkingUnit/EditorialObject/TimelineDecompositions/mp7:Mpeg7/mp7:Description/mp7:MultimediaContent/mp7:AudioVisual/mp7:TemporalDecomposition[2]/mp7:AudioVisualSegment[1]/mp7:Semantic/mp7:SemanticBase[2]/mp7:Label/mp7:Name	/BmfDatastructure:Datastructure/Bmf:BMFItem/BmfDict:MasterItem/BmfProgrammes:Item/BmfDict:ParticipantOfProductionElementBatch/BmfProgrammes:Others[1]/BmfDict:LegalPerson/BmfProgrammes:Organisation_WEAKREF
mp7:PersonType	OthersFunction	Semantic persons captured from the video/ speech to text transcript	/wu:WorkingUnit/EditorialObject/TimelineDecompositions/mp7:Mpeg7/mp7:Description/mp7:MultimediaContent/mp7:AudioVisual/mp7:TemporalDecomposition[2]/mp7:AudioVisualSegment[16]/mp7:Semantic/mp7:SemanticBase[1]/mp7:Agent/@xsi:type	/BmfDatastructure:Datastructure/Bmf:BMFItem/BmfDict:MasterItem/BmfProgrammes:Item/BmfDict:ParticipantOfProductionElementBatch/BmfProgrammes:Others[4]/BmfDict:OthersFunction
Name	LegalPerson:IndividualPerson_WEAKREF	Name of the semantic person	/wu:WorkingUnit/EditorialObject/TimelineDecompositions/mp7:Mpeg7/mp7:Description/mp7:MultimediaContent/mp7:AudioVisual/mp7:TemporalDecomposition[2]/mp7:AudioVisualSegment[16]/mp7:Semantic/mp7:SemanticBase[1]/mp7:Label/mp7:Name	/BmfDatastructure:Datastructure/Bmf:BMFItem/BmfDict:MasterItem/BmfProgrammes:Item/BmfDict:ParticipantOfProductionElementBatch/BmfProgrammes:Others[4]/BmfDict:LegalPerson/BmfProgrammes:IndividualPerson_WEAKREF
AV Technical Metadata				
File@format	Fileformat:Element	The format of the video essence	/wu:WorkingUnit/EditorialObject/Realisations/Material[1]/Source/File/@format	/BmfDatastructure:Datastructure/Bmf:BMFItem/BmfDict:MasterItem/BmfProgrammes:Item/BmfDict:ContentInstanceBatch/BmfProduction:ContentInstance[1]/BmfDict:ContentStorage/BmfProduction:ContentStorage/BmfDict:PackageBatch/BmfProduction:SourcePackage/BmfDict:Descriptor/BmfProduction:GenericPictureEssenceDescriptor/BmfDict:File/BmfProduction:NetworkLocator/BmfDict:Fileformat/BmfTypes:Element
	Fileformat:thesaurusID	Classification Scheme Reference		/BmfDatastructure:Datastructure/Bmf:BMFItem/BmfDict:MasterItem/BmfProgrammes:Item/BmfDict:ContentInstanceBatch/BmfProduction:ContentInstance[1]/BmfDict:ContentStorage/BmfProduction:ContentStorage/BmfDict:PackageBatch/BmfProduction:SourcePackage/BmfDict:Descriptor/BmfProduction:GenericPictureEssenceDescriptor/BmfDict:File/BmfProduction:NetworkLocator/BmfDict:Fileformat/BmfTypes:thesaurusID

File@name	URLString	File name of the video essence	/wu:WorkingUnit/EditorialObject/Realisations/Material[1]/Source/File/@name	/BmfDatastructure:Datastructure/Bmf:BFItem/BmfDict:MasterItem/BmfProgrammes:Item/BmfDict:ContentInstanceBatch/BmfProduction:ContentInstance[1]/BmfDict:ContentStorage/BmfProduction:ContentStorage/BmfDict:PackageBatch/BmfProduction:SourcePackage/BmfDict:Descriptor/BmfProduction:GenericPictureEssenceDescriptor/BmfDict:File/BmfProduction:NetworkLocator/rp210Elements:URLString
File@num_bytes_qty	BitRate	Bit rate of the video Essence	/wu:WorkingUnit/EditorialObject/Realisations/Material[1]/Source/File/@num_bytes_qty	/BmfDatastructure:Datastructure/Bmf:BFItem/BmfDict:MasterItem/BmfProgrammes:Item/BmfDict:ContentInstanceBatch/BmfProduction:ContentInstance[1]/BmfDict:ContentStorage/BmfProduction:ContentStorage/BmfDict:PackageBatch/BmfProduction:SourcePackage/BmfDict:Descriptor/BmfProduction:GenericPictureEssenceDescriptor/s377mGroups:ExtensionProperties/rp210Elements:BitRate
Material@duration		Duration used to calculate the bit rate	/wu:WorkingUnit/EditorialObject/Realisations/Material[1]/@duration	
File@format	Fileformat:Element	The format of the audio essence	/wu:WorkingUnit/EditorialObject/Realisations/Material[2]/Source/File/@format	/BmfDatastructure:Datastructure/Bmf:BFItem/BmfDict:MasterItem/BmfProgrammes:Item/BmfDict:ContentInstanceBatch/BmfProduction:ContentInstance[2]/BmfDict:ContentStorage/BmfProduction:ContentStorage/BmfDict:PackageBatch/BmfProduction:SourcePackage/BmfDict:Descriptor/BmfProduction:GenericSoundEssenceDescriptor/BmfDict:File/BmfProduction:NetworkLocator/BmfDict:Fileformat/BmfTypes:Element
	Fileformat:thesaurusID	Classification Scheme Reference		/BmfDatastructure:Datastructure/Bmf:BFItem/BmfDict:MasterItem/BmfProgrammes:Item/BmfDict:ContentInstanceBatch/BmfProduction:ContentInstance[2]/BmfDict:ContentStorage/BmfProduction:ContentStorage/BmfDict:PackageBatch/BmfProduction:SourcePackage/BmfDict:Descriptor/BmfProduction:GenericSoundEssenceDescriptor/BmfDict:File/BmfProduction:NetworkLocator/BmfDict:Fileformat/BmfTypes:thesaurusID
File@name	URLString	File name of the audio essence	/wu:WorkingUnit/EditorialObject/Realisations/Material[2]/Source/File/@name	/BmfDatastructure:Datastructure/Bmf:BFItem/BmfDict:MasterItem/BmfProgrammes:Item/BmfDict:ContentInstanceBatch/BmfProduction:ContentInstance[2]/BmfDict:ContentStorage/BmfProduction:ContentStorage/BmfDict:PackageBatch/BmfProduction:SourcePackage/BmfDict:Descriptor/BmfProduction:GenericSoundEssenceDescriptor/BmfDict:File/BmfProduction:NetworkLocator/rp210Elements:URLString
File@num_bytes_qty	BitRate	Bitrate of the audio Essence	/wu:WorkingUnit/EditorialObject/Realisations/Material[2]/Source/File/@num_bytes_qty	/BmfDatastructure:Datastructure/Bmf:BFItem/BmfDict:MasterItem/BmfProgrammes:Item/BmfDict:ContentInstanceBatch/BmfProduction:ContentInstance[2]/BmfDict:ContentStorage/BmfProduction:ContentStorage/BmfDict:PackageBatch/BmfProduction:SourcePackage/s377mGroups:ExtensionProperties/rp210Elements:BitRate
Material@duration			/wu:WorkingUnit/EditorialObject/Realisations/Material[2]/@duration	
MediaUri	URLString	Key frame file url	/wu:WorkingUnit/EditorialObject/TimelineDecompositions/mp7:Mpeg7/mp7:Description/mp7:MultimediaContent/mp7:AudioVisual/mp7:MediaSourceDecomposition/mp7:VideoSegment/mp7:TemporalDecomposition/mp7:VideoSegment[1]/mp7:TemporalDecomposition[1]/mp7:VideoSegment/mp7:MediaLocator/mp7:MediaUri	/BmfDatastructure:Datastructure/Bmf:BFItem/BmfDict:MasterItem/BmfProgrammes:Item/BmfDict:AnnotationTrackBatch/BmfAnnotation:AnnotationTrack/BmfDict:AnnotationSegmentBatch/BmfAnnotation:AnnotationSegment[1]/BmfDict:AnnotationBatch/BmfAnnotation:KeyPicture/s377mGroups:ExtensionProperties/rp210Elements:Locators/s377mGroups:NetworkLocator/rp210Elements:URLString
MediaTimePoint	AnnotationStartPosition	Key frame position in timeline of the program	/wu:WorkingUnit/EditorialObject/TimelineDecompositions/mp7:Mpeg7/mp7:Description/mp7:MultimediaContent/mp7:AudioVisual/mp7:MediaSourceDecomposition/mp7:VideoSegment/mp7:TemporalDecomposition/mp7:VideoSegment[1]/mp7:TemporalDecomposition[1]/m	/BmfDatastructure:Datastructure/Bmf:BFItem/BmfDict:MasterItem/BmfProgrammes:Item/BmfDict:AnnotationTrackBatch/BmfAnnotation:AnnotationTrack/BmfDict:AnnotationSegmentBatch/BmfAnnotation:AnnotationSegment[1]/BmfDict:AnnotationStartPosition

			p7:VideoSegment/mp7:MediaTime/mp7:MediaTimePoint	
--	--	--	--	--

Table 17 : Mapping table PrestoSpace / BMF

D BMF / TV-A Mapping Table

BMF	TVA	Description	BMF Element Path	TVA Element Path
MainTitle	Title[1]/text()	The main title of the program	/BmfDatastructure:Datastructure/Bmf:BMFItem/BmfDict:MasterItem/BmfProgrammes:Item/rp210Elements:MainTitle	/tva:TVAMain/tva:ProgramDescription/tva:ProgramInformationTable/tva:ProgramInformation/tva:BasicDescription/tva:Title[1]/text()
SecondaryTitle	Title[2]/text()	The second title of the program	/BmfDatastructure:Datastructure/Bmf:BMFItem/BmfDict:MasterItem/BmfProgrammes:Item/rp210Elements:SecondaryTitle	/tva:TVAMain/tva:ProgramDescription/tva:ProgramInformationTable/tva:ProgramInformation/tva:BasicDescription/tva:Title[2]/text()
RealisationFocus:Element	Genre[1]/tva:Name	The primary apparent intention in transmitting the programme	/BmfDatastructure:Datastructure/Bmf:BMFItem/BmfDict:MasterItem/BmfProgrammes:Item/BmfDict:Classification/BmfAnnotation:NonFictionalPresentationForm/BmfDict:RealisationFocus/BmfTypes:Element	/tva:TVAMain/tva:ProgramDescription/tva:ProgramInformationTable/tva:ProgramInformation/tva:BasicDescription/tva:Genre[1]/tva:Name
RealisationFocus:thesaurusID	Genre[1]/@href	Classification Scheme Reference	/BmfDatastructure:Datastructure/Bmf:BMFItem/BmfDict:MasterItem/BmfProgrammes:Item/BmfDict:Classification/BmfAnnotation:NonFictionalPresentationForm/BmfDict:RealisationFocus/BmfTypes:thesaurusID	/tva:TVAMain/tva:ProgramDescription/tva:ProgramInformationTable/tva:ProgramInformation/tva:BasicDescription/tva:Genre[1]/@href
NonFictionalPresentationFormType:Element	Genre[2]/tva:Name	This dimension is used to classify programmes as to their formal structure	/BmfDatastructure:Datastructure/Bmf:BMFItem/BmfDict:MasterItem/BmfProgrammes:Item/BmfDict:Classification/BmfAnnotation:NonFictionalPresentationForm/BmfDict:NonFictionalPresentationFormType/BmfTypes:Element	/tva:TVAMain/tva:ProgramDescription/tva:ProgramInformationTable/tva:ProgramInformation/tva:BasicDescription/tva:Genre[2]/tva:Name
NonFictionalPresentationFormType:thesaurusID	Genre[2]/@href	Classification Scheme Reference	/BmfDatastructure:Datastructure/Bmf:BMFItem/BmfDict:MasterItem/BmfProgrammes:Item/BmfDict:Classification/BmfAnnotation:NonFictionalPresentationForm/BmfDict:NonFictionalPresentationFormType/BmfTypes:thesaurusID	/tva:TVAMain/tva:ProgramDescription/tva:ProgramInformationTable/tva:ProgramInformation/tva:BasicDescription/tva:Genre[2]/@href
NonFictionalPresentationGenreBatch:Element:Element	Genre[3]/tva:Name	The genre of the item	/BmfDatastructure:Datastructure/Bmf:BMFItem/BmfDict:MasterItem/BmfProgrammes:Item/BmfDict:Classification/BmfAnnotation:NonFictionalPresentationForm/BmfDict:NonFictionalPresentationGenreBatch/BmfDict:Element/BmfTypes:Element	/tva:TVAMain/tva:ProgramDescription/tva:ProgramInformationTable/tva:ProgramInformation/tva:BasicDescription/tva:Genre[3]/tva:Name
NonFictionalPresentationGenreBatch:Element:thesaurusID	Genre[3]/@href	Classification Scheme Reference	/BmfDatastructure:Datastructure/Bmf:BMFItem/BmfDict:MasterItem/BmfProgrammes:Item/BmfDict:Classification/BmfAnnotation:NonFictionalPresentationForm/BmfDict:NonFictionalPresentationGenreBatch/BmfDict:Element/BmfTypes:thesaurusID	/tva:TVAMain/tva:ProgramDescription/tva:ProgramInformationTable/tva:ProgramInformation/tva:BasicDescription/tva:Genre[3]/@href
ItemEditorialTrack:Duration		The duration of the item	/BmfDatastructure:Datastructure/Bmf:BMFItem/BmfDict:MasterItem/BmfProgrammes:Item/BmfDict:ItemTrackArray/BmfProgrammes:ItemEditorialTrack/rp210Elements:Duration	/tva:TVAMain/tva:ProgramDescription/tva:ProgramLocationTable/tva:OnDemandProgram[1]/tva:PublishedDuration
PublicationStartDateandTime	PublishedStartTime	Publication date and time of the program	/BmfDatastructure:Datastructure/Bmf:BMFItem/BmfDict:MasterItem/BmfProgrammes:Item/BmfDict:PublicationBatch/BmfPublishing:Broadcast/BmfDict:PublicationStartDateandTime	/tva:TVAMain/tva:ProgramDescription/tva:ProgramLocationTable/tva:BroadcastEvent/tva:PublishedStartTime
	PublishedDuration			/tva:TVAMain/tva:ProgramDescription/tva:ProgramLocationTable/tva:BroadcastEvent/tva:PublishedDuration
ScriptingText	InlineTextContent	Transcript of the spoken text in the audio of the item	/BmfDatastructure:Datastructure/Bmf:BMFItem/BmfDict:MasterItem/BmfProgrammes:Item/BmfDict:ScriptBatch/BmfProgrammes:Script/rp210Elements:ScriptingText	/tva:TVAMain/tva:ProgramDescription/tva:ProgramInformationTable/tva:ProgramInformation/tva:BasicDescription/tva:RelatedMaterial[3]/tva:MediaLocator/notube:InlineTextContent
ExternalProductionIdentifierBatch:Element	ProgramInformation@programId	Identifier for the item	/BmfDatastructure:Datastructure/Bmf:BMFItem/BmfDict:MasterItem/BmfProgrammes:Item/BmfDict:ExternalProductionIdentifierBatch/BmfDict:Element	/tva:TVAMain/tva:ProgramDescription/tva:ProgramInformationTable/tva:ProgramInformation/@programId
RightsHolder:Organisation_WEAKREF	RightsOwner	Owner of the content right	/BmfDatastructure:Datastructure/Bmf:BMFItem/BmfDict:MasterItem/BmfProgrammes:Item/BmfDict:RightsBatch/BmfProgrammes:AvailableRights/BmfDict:RightsHolder/BmfProgrammes:Organisation_WEAKREF	/tva:TVAMain/tva:MetadataOriginationInformationTable/tva:MetadataOriginationInformation/tva:RightsOwner
ChannelName	ServiceInformation:Name	The name of the channel/service the program is broadcasted in	/BmfDatastructure:Datastructure/Bmf:BMFItem/BmfDict:MasterItem/BmfProgrammes:Item/BmfDict:PublicationBatch/BmfPublishing:Broadcast/BmfDict:ChannelName	/tva:TVAMain/tva:ProgramDescription/tva:ServiceInformationTable/tva:ServiceInformation/tva:Name

LocationKind	DepictedLocation: Role@href	Semantic places captured from the video/ speech to text transcript	/BmfDatastructure:Datastructure/Bmf:BMFItem/BmfDct:MasterItem/BmfProgrammes:Item/BmfDct:LocationBatch/BmfProgrammes:Location/BmfDct:LocationKind	/tva:TVAMain/tva:ProgramDescription/tva:ProgramInformationTable/tva:ProgramInformation/tva:BasicDescription/tva:DepictedCoordinates/tva:DepictedLocation/mpeg7:Role/@href
LocationDescription	DepictedLocation: Name	Name of the semantic place	/BmfDatastructure:Datastructure/Bmf:BMFItem/BmfDct:MasterItem/BmfProgrammes:Item/BmfDct:LocationBatch/BmfProgrammes:Location/rp210Elements:LocationDescription	/tva:TVAMain/tva:ProgramDescription/tva:ProgramInformationTable/tva:ProgramInformation/tva:BasicDescription/tva:DepictedCoordinates/tva:DepictedLocation/mpeg7:Name
OthersFunction	CreditsItem@role	Semantic organizations captured from the video/ speech to text transcript	/BmfDatastructure:Datastructure/Bmf:BMFItem/BmfDct:MasterItem/BmfProgrammes:Item/BmfDct:ParticipantOfProductionElementBatch/BmfProgrammes:Others[1]/BmfDct:OthersFunction	/tva:TVAMain/tva:ProgramDescription/tva:ProgramInformationTable/tva:ProgramInformation/tva:BasicDescription/tva:CreditsList/tva:CreditsItem[4]/@role
LegalPerson:Organisation_WEAKREF	CreditsItem:OrganisationName	name of the semantic organization	/BmfDatastructure:Datastructure/Bmf:BMFItem/BmfDct:MasterItem/BmfProgrammes:Item/BmfDct:ParticipantOfProductionElementBatch/BmfProgrammes:Others[1]/BmfDct:LegalPerson/BmfProgrammes:Organisation_WEAKREF	/tva:TVAMain/tva:ProgramDescription/tva:ProgramInformationTable/tva:ProgramInformation/tva:BasicDescription/tva:CreditsList/tva:CreditsItem[4]/tva:OrganizationName
OthersFunction	CreditsItem@role	Semantic persons captured from the video/ speech to text transcript	/BmfDatastructure:Datastructure/Bmf:BMFItem/BmfDct:MasterItem/BmfProgrammes:Item/BmfDct:ParticipantOfProductionElementBatch/BmfProgrammes:Others[4]/BmfDct:OthersFunction	/tva:TVAMain/tva:ProgramDescription/tva:ProgramInformationTable/tva:ProgramInformation/tva:BasicDescription/tva:CreditsList/tva:CreditsItem[1]/@role
LegalPerson:IndividualPerson_WEAKREF	CreditsItem:PersonName	Name of the semantic person	/BmfDatastructure:Datastructure/Bmf:BMFItem/BmfDct:MasterItem/BmfProgrammes:Item/BmfDct:ParticipantOfProductionElementBatch/BmfProgrammes:Others[4]/BmfDct:LegalPerson/BmfProgrammes:IndividualPerson_WEAKREF	/tva:TVAMain/tva:ProgramDescription/tva:ProgramInformationTable/tva:ProgramInformation/tva:BasicDescription/tva:CreditsList/tva:CreditsItem[1]/tva:PersonName
AV Technical Metadata				
Fileformat:Element	FileFormat:Name	The format of the video essence	/BmfDatastructure:Datastructure/Bmf:BMFItem/BmfDct:MasterItem/BmfProgrammes:Item/BmfDct:ContentInstanceBatch/BmfProduction:ContentInstance[1]/BmfDct:ContentStorage/BmfProduction:ContentStorage/BmfDct:PackageBatch/BmfProduction:SourcePackage/BmfDct:Descriptor/BmfProduction:GenericPictureEssenceDescriptor/BmfDct:File/BmfProduction:NetworkLocator/BmfDct:Fileformat/BmfTypes:Element	/tva:TVAMain/tva:ProgramDescription/tva:ProgramLocationTable/tva:OnDemandProgram[1]/tva:InstanceDescription/tva:AVAttributes/tva:FileFormat/tva:Name
Fileformat:thesaurusID	FileFormat@href	Classification Scheme Reference	/BmfDatastructure:Datastructure/Bmf:BMFItem/BmfDct:MasterItem/BmfProgrammes:Item/BmfDct:ContentInstanceBatch/BmfProduction:ContentInstance[1]/BmfDct:ContentStorage/BmfProduction:ContentStorage/BmfDct:PackageBatch/BmfProduction:SourcePackage/BmfDct:Descriptor/BmfProduction:GenericPictureEssenceDescriptor/BmfDct:File/BmfProduction:NetworkLocator/BmfDct:Fileformat/BmfTypes:thesaurusID	/tva:TVAMain/tva:ProgramDescription/tva:ProgramLocationTable/tva:OnDemandProgram[1]/tva:InstanceDescription/tva:AVAttributes/tva:FileFormat/@href
URLString	ProgramURL	File name of the video essence	/BmfDatastructure:Datastructure/Bmf:BMFItem/BmfDct:MasterItem/BmfProgrammes:Item/BmfDct:ContentInstanceBatch/BmfProduction:ContentInstance[1]/BmfDct:ContentStorage/BmfProduction:ContentStorage/BmfDct:PackageBatch/BmfProduction:SourcePackage/BmfDct:Descriptor/BmfProduction:GenericPictureEssenceDescriptor/BmfDct:File/BmfProduction:NetworkLocator/rp210Elements:URLString	/tva:TVAMain/tva:ProgramDescription/tva:ProgramLocationTable/tva:OnDemandProgram[1]/tva:ProgramURL
BitRate	BitRate	Bitrate of the video Essence	/BmfDatastructure:Datastructure/Bmf:BMFItem/BmfDct:MasterItem/BmfProgrammes:Item/BmfDct:ContentInstanceBatch/BmfProduction:ContentInstance[1]/BmfDct:ContentStorage/BmfProduction:ContentStorage/BmfDct:PackageBatch/BmfProduction:SourcePackage/BmfDct:Descriptor/BmfProduction:GenericPictureEssenceDescriptor/s377mGroups:ExtensionProperties/rp210Elements:BitRate	/tva:TVAMain/tva:ProgramDescription/tva:ProgramLocationTable/tva:OnDemandProgram[1]/tva:InstanceDescription/tva:AVAttributes/tva:BitRate
Fileformat:Element	FileFormat:Name	The format of the audio essence	/BmfDatastructure:Datastructure/Bmf:BMFItem/BmfDct:MasterItem/BmfProgrammes:Item/BmfDct:ContentInstanceBatch/BmfProduction:ContentInstance[2]/BmfDct:ContentStorage/BmfProduction:ContentStorage/BmfDct:PackageBatch/BmfProduction:SourcePackage/BmfDct:Descriptor/BmfProduction:	/tva:TVAMain/tva:ProgramDescription/tva:ProgramLocationTable/tva:OnDemandProgram[2]/tva:InstanceDescription/tva:AVAttributes/tva:FileFormat/tva:Name

			GenericSoundEssenceDescriptor/BmfDict:File/BmfProduction:NetworkLocator/BmfDict:Fileformat/BmfTypes:Element	
Fileformat:thesaurusID	FileFormat@href	Classification Scheme Reference	/BmfDatastructure:Datastructure/Bmf:BMFItem/BmfDict:MasterItem/BmfProgrammes:Item/BmfDict:ContentInstanceBatch/BmfProduction:ContentInstance[2]/BmfDict:ContentStorage/BmfProduction:ContentStorage/BmfDict:PackageBatch/BmfProduction:SourcePackage/BmfDict:Descriptor/BmfProduction:GenericSoundEssenceDescriptor/BmfDict:File/BmfProduction:NetworkLocator/BmfDict:Fileformat/BmfTypes:thesaurusID	/tva:TVAMain/tva:ProgramDescription/tva:ProgramLocationTable/tva:OnDemandProgram[2]/tva:InstanceDescription/tva:AVAttributes/tva:FileFormat/@href
URLString	ProgramURL	File name of the audio essence	/BmfDatastructure:Datastructure/Bmf:BMFItem/BmfDict:MasterItem/BmfProgrammes:Item/BmfDict:ContentInstanceBatch/BmfProduction:ContentInstance[2]/BmfDict:ContentStorage/BmfProduction:ContentStorage/BmfDict:PackageBatch/BmfProduction:SourcePackage/BmfDict:Descriptor/BmfProduction:GenericSoundEssenceDescriptor/BmfDict:File/BmfProduction:NetworkLocator/rp210Elements:URLString	/tva:TVAMain/tva:ProgramDescription/tva:ProgramLocationTable/tva:OnDemandProgram[2]/tva:ProgramURL
BitRate	BitRate	Bitrate of the audio Essence	/BmfDatastructure:Datastructure/Bmf:BMFItem/BmfDict:MasterItem/BmfProgrammes:Item/BmfDict:ContentInstanceBatch/BmfProduction:ContentInstance[2]/BmfDict:ContentStorage/BmfProduction:ContentStorage/BmfDict:PackageBatch/BmfProduction:SourcePackage/s377mGroups:ExtensionProperties/rp210Elements:BitRate	/tva:TVAMain/tva:ProgramDescription/tva:ProgramLocationTable/tva:OnDemandProgram[2]/tva:InstanceDescription/tva:AVAttributes/tva:BitRate
URLString	TitleImage:MediaUri	Key frame file url	/BmfDatastructure:Datastructure/Bmf:BMFItem/BmfDict:MasterItem/BmfProgrammes:Item/BmfDict:AnnotationTrackBatch/BmfAnnotation:AnnotationTrack/BmfDict:AnnotationSegmentBatch/BmfAnnotation:AnnotationSegment[1]/BmfDict:AnnotationBatch/BmfAnnotation:KeyPicture/s377mGroups:ExtensionProperties/rp210Elements:Locators/s377mGroups:NetworkLocator/rp210Elements:URLString	/tva:TVAMain/tva:ProgramDescription/tva:ProgramInformationTable/tva:ProgramInformation/tva:BasicDescription/tva:RelatedMaterial[1]/tva:PromotionalMedia/mpeg7:TitleImage/mpeg7:MediaUri
AnnotationStartPosition	TitleImage:MediaTimePoint	Key frame position in timeline of the program	/BmfDatastructure:Datastructure/Bmf:BMFItem/BmfDict:MasterItem/BmfProgrammes:Item/BmfDict:AnnotationTrackBatch/BmfAnnotation:AnnotationTrack/BmfDict:AnnotationSegmentBatch/BmfAnnotation:AnnotationSegment[1]/BmfDict:AnnotationStartPosition	/tva:TVAMain/tva:ProgramDescription/tva:ProgramInformationTable/tva:ProgramInformation/tva:BasicDescription/tva:RelatedMaterial[1]/tva:PromotionalMedia/mpeg7:TitleImage/mpeg7:MediaTimePoint

Table 18 : Mapping table BMF / TV-A

E EGTA / TV-A Mapping Table

EGTA	TVA	Description	EGTA Element Path	TVA Element Path
Title	Title[1]/text()	The main title of the program	/egtaMETA:egtaMETA/egtaMETA:spot/ebucore:title	/tva:TVAMain/tva:ProgramDescription/tva:ProgramInformationTable/tva:ProgramInformation/tva:BasicDescription/tva:Title[1]/text()
AlternativeTitle	Title[2]/text()	The second title of the program	/egtaMETA:egtaMETA/egtaMETA:spot/ebucore:alternativeTitle	/tva:TVAMain/tva:ProgramDescription/tva:ProgramInformationTable/tva:ProgramInformation/tva:BasicDescription/tva:Title[2]/text()
Description[main]	Synopsis[short]	Short description	/egtaMETA:egtaMETA/egtaMETA:spot/ebucore:description[main]	/tva:TVAMain/tva:ProgramDescription/tva:ProgramInformationTable/tva:ProgramInformation/tva:BasicDescription/tva:Synopsis length="short">
Description[spot text]	Synopsis[long]	Long description	/egtaMETA:egtaMETA/egtaMETA:spot/ebucore:description[spot text]	/tva:TVAMain/tva:ProgramDescription/tva:ProgramInformationTable/tva:ProgramInformation/tva:BasicDescription/tva:Synopsis length="long">
Subject	Keyword	Keyword	/egtaMETA:egtaMETA/egtaMETA:spot/ebucore:subject/dc:subject>	/tva:TVAMain/tva:ProgramDescription/tva:ProgramInformationTable/tva:ProgramInformation/tva:BasicDescription/tva:Keyword
Creator				
OrganizationName	OrganizationName	Creator organization name	/egtaMETA:egtaMETA/egtaMETA:spot/ebucore:creator/ebucore:organisationDetails/ebucore:organisationName	/tva:TVAMain/tva:ProgramDescription/tva:ProgramInformationTable/tva:ProgramInformation/tva:BasicDescription/tva:CreditsList/tva:CreditsItem/tva:OrganizationName
OrganizationId	OrganizationNameIDRef	Creator organization Id	/egtaMETA:egtaMETA/egtaMETA:spot/ebucore:creator/ebucore:organisationDetails:organisationId	/tva:TVAMain/tva:ProgramDescription/tva:ProgramInformationTable/tva:ProgramInformation/tva:BasicDescription/tva:CreditsList/tva:CreditsItem/tva:OrganizationNameIDRef
Advertiser				
OrganizationName	OrganizationName	Advertiser organization name	/egtaMETA:egtaMETA/egtaMETA:spot/ebucore:creator/ebucore:organisationDetails/ebucore:organisationName	/tva:TVAMain/tva:ProgramDescription/tva:ProgramInformationTable/tva:ProgramInformation/tva:BasicDescription/tva:CreditsList/tva:CreditsItem/tva:OrganizationName
OrganizationId	OrganizationNameIDRef	Advertiser organization Id	/egtaMETA:egtaMETA/egtaMETA:spot/ebucore:creator/ebucore:organisationDetails:organisationId	/tva:TVAMain/tva:ProgramDescription/tva:ProgramInformationTable/tva:ProgramInformation/tva:BasicDescription/tva:CreditsList/tva:CreditsItem/tva:OrganizationNameIDRef
Director				
GivenName	GivenName	Director name	/egtaMETA:egtaMETA/egtaMETA:spot/ebucore:creator/ebucore:organisationDetails/ebucore:contacts/ebucore:role typeLabel="Director"	/tva:TVAMain/tva:ProgramDescription/tva:ProgramInformationTable/tva:ProgramInformation/tva:BasicDescription/tva:CreditsList/tva:CreditsItem/tva:PersonName/mpeg7:GivenName
Producer				
OrganizationName	OrganizationName	Producer organization name	/egtaMETA:egtaMETA/egtaMETA:spot/ebucore:creator/ebucore:organisationDetails/ebucore:organisationName	/tva:TVAMain/tva:ProgramDescription/tva:ProgramInformationTable/tva:ProgramInformation/tva:BasicDescription/tva:CreditsList/tva:CreditsItem/tva:OrganizationName
OrganizationId	OrganizationNameIDRef	Producer organization Id	/egtaMETA:egtaMETA/egtaMETA:spot/ebucore:creator/ebucore:organisationDetails:organisationId	/tva:TVAMain/tva:ProgramDescription/tva:ProgramInformationTable/tva:ProgramInformation/tva:BasicDescription/tva:CreditsList/tva:CreditsItem/tva:OrganizationNameIDRef
GivenName	GivenName	Producer name	/egtaMETA:egtaMETA/egtaMETA:spot/ebucore:creator/ebucore:organisationDetails/ebucore:contacts/ebucore:role typeLabel="Director"	/tva:TVAMain/tva:ProgramDescription/tva:ProgramInformationTable/tva:ProgramInformation/tva:BasicDescription/tva:CreditsList/tva:CreditsItem/tva:PersonName/mpeg7:GivenName
Actor				
OrganizationName	OrganizationName	Actor organization name	/egtaMETA:egtaMETA/egtaMETA:spot/ebucore:creator/ebucore:organisationDetails/ebucore:organisationName	/tva:TVAMain/tva:ProgramDescription/tva:ProgramInformationTable/tva:ProgramInformation/tva:BasicDescription/tva:CreditsList/tva:CreditsItem/tva:OrganizationName
OrganizationId	OrganizationNameIDRef	Actor organization Id	/egtaMETA:egtaMETA/egtaMETA:spot/ebucore:creator/ebucore:organisationDetails:organisationId	/tva:TVAMain/tva:ProgramDescription/tva:ProgramInformationTable/tva:ProgramInformation/tva:BasicDescription/tva:CreditsList/tva:CreditsItem/tva:OrganizationNameIDRef

GivenName	GivenName	Actor given name	/egtaMETA:egtaMETA/egtaMETA:spot/ebucore:creator/ebucore:organisationDetails/ebucore:contacts/ebucore:roleTypeLabel="Director"	/tva:TVAMain/tva:ProgramDescription/tva:ProgramInformationTable/tva:ProgramInformation/tva:BasicDescription/tva:CreditsList/tva:CreditsItem/tva:PersonName/mpeg7:GivenName
FamilyName	FamilyName	Actor family name	/egtaMETA:egtaMETA/egtaMETA:spot/ebucore:creator/ebucore:organisationDetails/ebucore:contacts/ebucore:roleTypeLabel="Director"	/tva:TVAMain/tva:ProgramDescription/tva:ProgramInformationTable/tva:ProgramInformation/tva:BasicDescription/tva:CreditsList/tva:CreditsItem/tva:PersonName/mpeg7:FamilyName
AV Technical Metadata				
FileFormat	fileFormat	Format of video/audio file	/egtaMETA:egtaMETA/egtaMETA:spot/ebucore:format/@formatDefinition	/tva:TVAMain/tva:ProgramDescription/tva:ProgramLocationTable/tva:OnDemandProgram[1]/tva:InstanceDescription/tva:AVAttributes/tva:FileFormat/tva:Name
FileSize	fileSize	Size of video/audio file	/egtaMETA:egtaMETA/egtaMETA:spot/ebucore:format/ebucore:fileSize	/tva:TVAMain/tva:ProgramDescription/tva:ProgramLocationTable/tva:OnDemandProgram[1]/tva:InstanceDescription/tva:AVAttributes/tva:FileSize
Locator/filename	ProgramURL	URL of the video/audio file	/egtaMETA:egtaMETA/egtaMETA:spot/ebucore:format/ebucore:location/egtaMETA:egtaMETA/egtaMETA:spot/ebucore:format/ebucore:fileName	/tva:TVAMain/tva:ProgramDescription/tva:ProgramLocationTable/tva:OnDemandProgram[1]/tva:ProgramURL
Width	Horizontal size	Video width	/egtaMETA:egtaMETA/egtaMETA:spot/ebucore:format/ebucore:width	/tva:TVAMain/tva:ProgramDescription/tva:ProgramLocationTable/tva:OnDemandProgram[1]/tva:InstanceDescription/tva:AVAttributes/tva:VideoAttributes/tva:HorizontalSize
Height	Vertical Size	Video height	/egtaMETA:egtaMETA/egtaMETA:spot/ebucore:format/ebucore:height	/tva:TVAMain/tva:ProgramDescription/tva:ProgramLocationTable/tva:OnDemandProgram[1]/tva:InstanceDescription/tva:AVAttributes/tva:VideoAttributes/tva:VerticalSize
AspectRatio	aspectRatio	Aspect ratio	/egtaMETA:egtaMETA/egtaMETA:spot/ebucore:format/ebucore:videoFormat/ebucore:aspectRatio	/tva:TVAMain/tva:ProgramDescription/tva:ProgramLocationTable/tva:OnDemandProgram[1]/tva:InstanceDescription/tva:AVAttributes/tva:VideoAttributes/tva:AspectRatio
videoEncoding	Coding:Name	Video encoding type	/egtaMETA:egtaMETA/egtaMETA:spot/ebucore:format/ebucore:videoFormat/ebucore:videoEncoding	/tva:TVAMain/tva:ProgramDescription/tva:ProgramLocationTable/tva:OnDemandProgram[1]/tva:InstanceDescription/tva:AVAttributes/tva:VideoAttributes/tva:coding/tva:Name
audioEncoding	Coding:Name	Audio encoding type	/egtaMETA:egtaMETA/egtaMETA:spot/ebucore:format/ebucore:videoFormat/ebucore:audioEncoding	/tva:TVAMain/tva:ProgramDescription/tva:ProgramLocationTable/tva:OnDemandProgram[1]/tva:InstanceDescription/tva:AVAttributes/tva:AudioAttributes/tva:coding/tva:Name
Preview image				
egtaMETA:pictureContainer	InlineMedia:Media Data64	Media data of preview image	/egtaMETA:egtaMETA/egtaMETA:spot/egtaMETA:picture/egtaMETA:PictureContainer	/tva:TVAMain/tva:ProgramDescription/tva:ProgramInformationTable/tva:ProgramInformation/tva:BasicDescription/tva:RelatedMaterial/tva:PromotionalMedia/mpeg7:TitleImage/mpeg7:InlineMedia/mpeg7:MediaData64